



## INDUSTRIAL TOUCH SCREEN MONITOR

## VIO-W215-MX200

15.6" Full HD 16:9 Resistive / Capacitive Touch Monitor with 2x 10W Speaker



## Features

- 15.6" Full HD 16:9 LCD with resistive 5-wire / projected capacitive touch
- 1x VGA, 1x HDMI, 1x DisplayPort, 1x USB 2.0, 1x COM, 1x Audio
- 9 to 48VDC wide range power input
- -10°C to 60°C extended operating temperature
- Designed with aluminum die-casting front frame
- IP65 compliant front panel
- Two 10W internal speakers built-in
- Multi-language OSD built-in

## Specifications

Display	
IP Rating	IP65
LCD Size	15.6" (16:9)
Max. Resolution	1920 x 1080 (FHD)
Brightness (cd/m <sup>2</sup> )	500 / 1000 (optional)
Contrast Ratio	1000:1
LCD Color	16.7M
Pixel Pitch (mm)	0.17925(H) x 0.17925(V)
Viewing Angle	178/178
Backlight MTBF	50000 hrs (LED Backlight)
Touch	
Projected Capacitive	VIO-W215C-MX200
Resistive 5-Wire	VIO-W215R-MX200
I/O	
Audio	1x Audio Input
COM	1x COM Port Input (Resistive Touch Only)
USB	1x USB 2.0 (For Resistive Touch or P-CAP Touch)
DP	1x DisplayPort
HDMI	1x HDMI
VGA	1x VGA
Others Features	
Speaker	AMP 10W + 10W
OSD	LCD On/Off, Auto, Menu, Up and Down Multi-language
Power	
Power Adapter	Optional AC/DC 12V/5A, 60W
Power Management	Power Ignition Management
Power Mode	AT, ATX
Power Supply Voltage	9~48 VDC
Power Connector	3-Pin Terminal Block
Power Protection	OVP (Over Voltage Protection) OCP (Over Current Protection) Reverse Protection
Operating Temperature	-10 °C ~ 60 °C
Storage Temperature	-20 °C to 70 °C
Relative Humidity	10% ~ 80% (non-condensing)
IP Level	IP 65 Compliant Front Panel
Certification	CE, FCC Class A
Vibration	1.5 Grms, 5 - 500 Hz, 0.5 hr/axis
Shock	20G, half sine, 11ms
Physical	
Dimensions	398 (W) x 247 (D) x 70.7 (H) mm
Weights	4.99 kg ~ 5.11 kg
Mounting Options	VESA Mounting Holes 75 x 75mm, 100 x 100mm

## Available Models

- VIO-W215R-MX200  
15.6" 16:9 FHD Resistive Touch Thin Frame Monitor with 2x 10W Speaker
- VIO-W215C-MX200  
15.6" 16:9 FHD Capacitive Touch Thin Frame Monitor with 2x 10W Speaker

## Optional Accessories

- 1-E09A06008  
Adapter AC/DC 12V 5A 60W with 3pin Terminal Block Plug 5.0mm Pitch
- SFICBL022  
Power Cord, 3-pin US Type, 180cm
- 1-TPCD00002  
Power Cord, European Type
- 1-TPCD00001  
Power Cord, 3-pin UK Type, 180cm

## Packing List

- 1x VIO-W215-MX200 Touch Monitor
- 8x Panel Mount Kit
- 1x USB Cable
- 1x VGA Cable
- 1x Screw Pack

\* All specifications and photos are subject to change without notice.

## External I/O Mechanical Layout

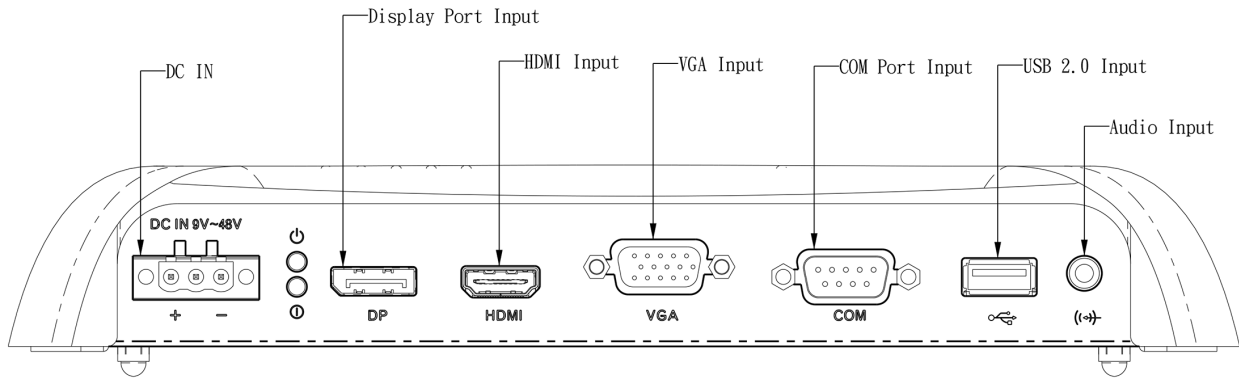

## Dimension

Unit: mm

