

R15IB3S-65A1FTP

15" Intel® Celeron® N2930 IP65 Stainless PCAP Chassis Panel PC



KEY FEATURES

- Full IP65 dust/water resistant
- Robust and fanless design for reliable operation
- Fanless Colling System and Ultra Low power consumption
- Support Intel® Celeron® N2930 Processor
- SUS 316/ AISI 316 stainless steel for food and chemical industries
- Special Flat Touch Design easy to maintain
- Projective Capacitive Touch
- Optical bonding (optional)



OVERVIEW



Waterproof All-Around

The Panel PC complies with IP65 water and dust resistance for regular cleanup processes and strict hygiene standards in the Food, Beverage, and Pharmaceutical industries.



Comprehensive Stainless Solution

The wide range of stainless human-machine interfaces (HMI) and Panel PCs are widely used for automation processes in Food & Beverage applications and chemical factories.



Projected Capacitive Multi-Touch (P-CAP)

The highly-sensitive touch screen and PCAP multi-touch support make it easy for users to key in data, rotate images, drag and drop files, and zoom in with two or more fingers.



Chassis Design

The covered chassis design for the touch screen display is stylish and supports different mounting brackets for easy installation.

SPECIFICATIONS

Display			
Resolution	1024x768	Size	15.0 inches
Contrast Ratio	2500:1	Panel Brightness	500.0 nits
View Angles	88,88,88,88	Active Area	304.1x228.1 mm
Touch / Glass	Projected Capacitive Multi Touch Screen		
System Specification			
Processor	Intel Celeron N2930 1.83GHz (up to 2.16GHz)	Memory	1 x SO-DIMM, DDR3L 1600 MHz, 4GB 8GB (Optional)
Storage	1 x mSATA SSD 128GB 256GB (Optional) 512GB (Optional)	Ethernet controller	2 x Intel® Ethernet Controller

Operating System	Windows 10 IoT Enterprise (64 bit) (Optional) Linux Ubuntu 20.04 (Optional)	WLAN	Support (Optional)
BT	Support (Optional)		
Mechanical			
Dimension	396 x 310 x 49 mm	Weight	5.7 kg
Mounting	VESA Mount	Enclosure	Stainless Housing
Cooling System	Fanless design		
Environment			
Operating Humidity	10% to 90% RH, Non-Condensing	Operating Temperature	0°C to 45°C
Storage Temperature	-20°C to 60°C	IP rating	IP65
Certification			
Certification	CE, FCC		
IO Ports			
Power Input	1 x M12 waterproof connector for 12V DC	USB Port	1x M12 waterproof connector for 2 x USB2.0
Serial Port	1 x M12 waterproof connector for RS232	LAN	1 x waterproof Giga LAN RJ45 connector
Indicator	1 x LED Indicator for power 1 x LED Indicator for storage		
Control			
Button	1 x Power Button 1 x Reset Button		
Accessory			
Accessory	External USB cable with waterproof connector External COM cable with waterproof connector External LAN cable with waterproof connector Waterproof caps VESA screws 100~240V AC to DC Adapter with waterproof connector Power Cord		
Power			
Power Rating	12V DC (M12 type)		

DIMENSIONS UNIT:MM

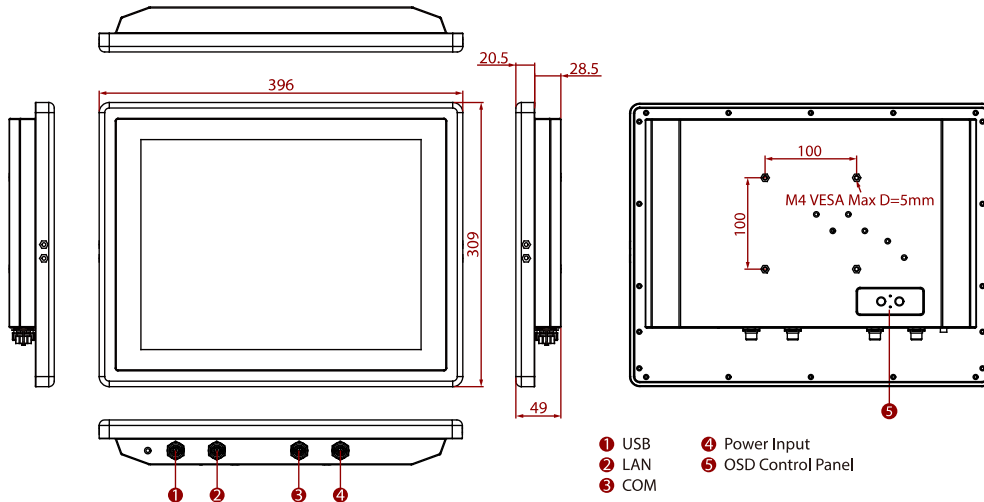

NOTE

1. This is a simplified drawing and some components are not marked in detail.
2. Windows 10 operating system requires installing a new version of BIOS and OS image.
3. Windows 7 does not support the TPM 2.0 function.
4. The product shown in this datasheet is a standard model. For diagrams that contain customized or optional I/O, please contact the Winmate Sales Team for more information.
5. All specifications are subject to change without prior notice.

Assured Systems

Assured Systems is a leading technology company with over 1,500 regular clients in 80 countries, deploying over 85,000 systems to a diverse customer base in 12 years of business. We offer high-quality and innovative rugged computing, display, networking and data collection solutions to the embedded, industrial, and digital-out-of-home market sectors.

US

sales@assured-systems.com

Sales: +1 347 719 4508
Support: +1 347 719 4508

1309 Coffeen Ave
Ste 1200
Sheridan
WY 82801
USA

EMEA

sales@assured-systems.com

Sales: +44 (0)1785 879 050
Support: +44 (0)1785 879 050

Unit A5 Douglas Park
Stone Business Park
Stone
ST15 0YJ
United Kingdom

VAT Number: 120 9546 28
Business Registration Number: 07699660