

15" Multi-Touch Chassis Display - R15L100-PTC3-PoE

Features

- 15" 1024 x 768 Resolution
- Front side strengthened glass
- VGA input and HDMI input
- Stylish and elegant design
- Supports PoE

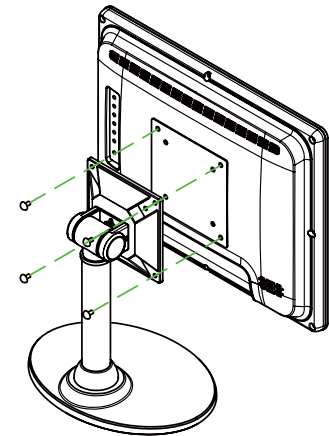
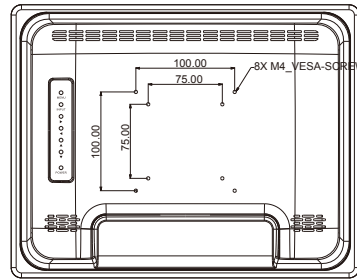
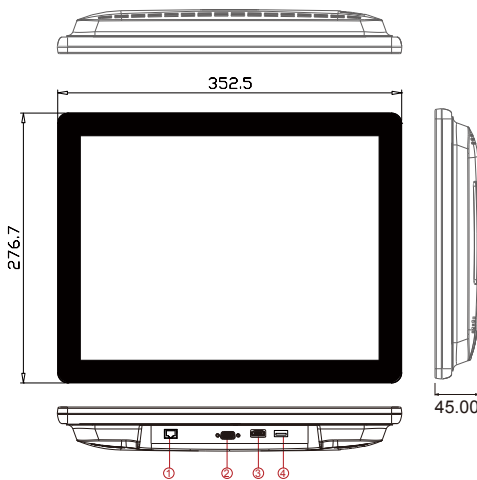

1. PoE for Power Input
2. VGA
3. HDMI
4. USB for touch

VESA Desk Stand (optional)

* Note: this is a simplified drawing and some components are not marked in detail. Please contact our sales representative if you need further product information.

Specifications

Display Spec :

- Size/Type : 15" TFT
- Resolutions : 1024x768
- Brightness : 300cd/m² (typ.)
- Contrast Ratio : 700 : 1 (typ.)
- Viewing Angle : -80~80(H);-80~80(V)
- Max Colors : 16.2M
- Front side glass : Optional
- Touch screen : Projected-Capacitive Touch
Optional anti-glare coating

Power Specification :

- Power Input/Power Over Ethernet : Power Device (PD) follows IEEE 802.3at (25 W), IEEE 802.3af (15 W)
- Power Consumption : 10W typical, normal operation

Environment Considerations :

- Operating Temperature : 0 °C to 40 °C
- LCD panel life time : 50,000 hours
- Certification : CE, FCC Class A, UL, RoHS

Input Specifications :

- Input Ports : 1 x VGA
1 x HDMI
1 x PoE for Power Input
1 x USB for touch
- OSD Membrane : Buttons at the back side
- Speaker : 2 x 1 Watt (Optional)

Mechanical Specification :

- Mounting : VESA Mount (100x100mm, 75x75mm)
- Dimensions (W x H x D) : 352.5 x 276.7 x 45 (mm)
- Appearance : Plastic casing

Product Accessory :

- Accessory : HDMI cable
VGA cable
USB cable for touch

Assured Systems

Assured Systems is a leading technology company with over 1,500 regular clients in 80 countries, deploying over 85,000 systems to a diverse customer base in 12 years of business. We offer high-quality and innovative rugged computing, display, networking and data collection solutions to the embedded, industrial, and digital-out-of-home market sectors.

US

sales@assured-systems.com

Sales: +1 347 719 4508
Support: +1 347 719 4508

1309 Coffeen Ave
Ste 1200
Sheridan
WY 82801
USA

EMEA

sales@assured-systems.com

Sales: +44 (0)1785 879 050
Support: +44 (0)1785 879 050

Unit A5 Douglas Park
Stone Business Park
Stone
ST15 0YJ
United Kingdom

VAT Number: 120 9546 28
Business Registration Number: 07699660