



Industrial Solutions Partner!

**DLF/DLH1015-A V1**

**10.1" TFT LCD, LED Backlight 1000nits, 1280x800**

The DLF/DLH1015-A is a 10.1 inch industrial grade sunlight readable LCD, with high brightness 1000 nits and high color saturation, it produce sharp images, crisp text and lifelike colors. The Durapixel LED backlight technology ensures high reliability and low power consumption, suitable for outdoor application, kiosk, factory automation, military, transportation and gaming application.

**Key Features**

- High Brightness 1000 nits
- Sunlight Readable
- LED Backlight
- Low Power Consumption
- Wide Operation Temperature
- BL MTBF: 100,000 hours



**Specifications**

|                                 |  |
|---------------------------------|--|
| <b>Model Name</b>               | <b>DLF/DLH1015-A V1</b>                                      |
| <b>Description</b>              | 10.1" TFT LCD, LED Backlight 1000 nits, 1280x800             |
| <b>Screen Size</b>              | 10.1"  |
| <b>Display Area (mm)</b>        | 216.96(H) x 135.6(V)   |
| <b>Brightness</b>               | 1000 cd/m <sup>2</sup>                                       |
| <b>Resolution</b>               | 1280x800   |
| <b>Aspect Ratio</b>             | 16 : 10  |
| <b>Contrast Ratio</b>           | 1400 : 1   |
| <b>Pixel Pitch (mm)</b>         | 0.1695(H) x 0.1695(V)  |
| <b>Pixel Pre Inch (PPI)</b>     | 149  |
| <b>Viewing Angle</b>            | 170°(H),170°(V)  |
| <b>Color Saturation (NTSC)</b>  | 52%  |
| <b>Display Colors</b>           | 16.2M  |
| <b>Response Time (Typical)</b>  | 25ms   |
| <b>Panel Interface</b>          | LVDS   |
| <b>AD Board Input Interface</b> | DVI-I, HDMI, DP  |
| <b>AD Board Input Power</b>     | DC12V  |
| <b>Power Consumption</b>        | 8.2W (9W with AD board)                                      |
| <b>OSD Key</b>                  | 4 Keys (Power Switch, Menu, +, -)                            |
| <b>OSD Control</b>              | Brightness, Color, Contrast, Auto Turing, H/V Position...etc |
| <b>Dimensions (mm)</b>          | 227.91(H) x 148(V)x7.6 (T)                                   |
| <b>Bezel Size(U/B/L/R)</b>      | 3.55/6.85/3.4/5.55 mm  |
| <b>Weight (Net)</b>             | 0.8kg  |
| <b>Operating Temperature</b>    | -20 °C ~ 70 °C   |
| <b>Storage Temperature</b>      | -30 °C ~ 80 °C   |

**DLF** = Panel + LED Driving Board

**DLH** = Panel + LED Driving Board + AD Control Board

Specifications are subject to change without notice.  
All brands or product names are trademarks or registered trademarks of their respective companies.



Industrial Solutions Partner!

**Mechanical Drawing**

**Outline Dimensions**

Unit:mm

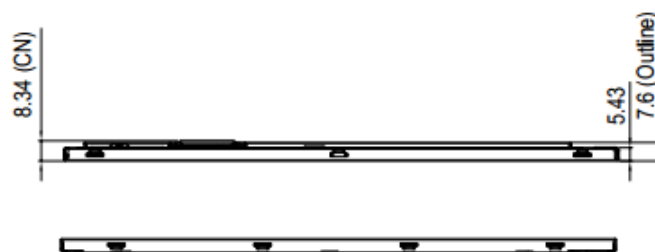
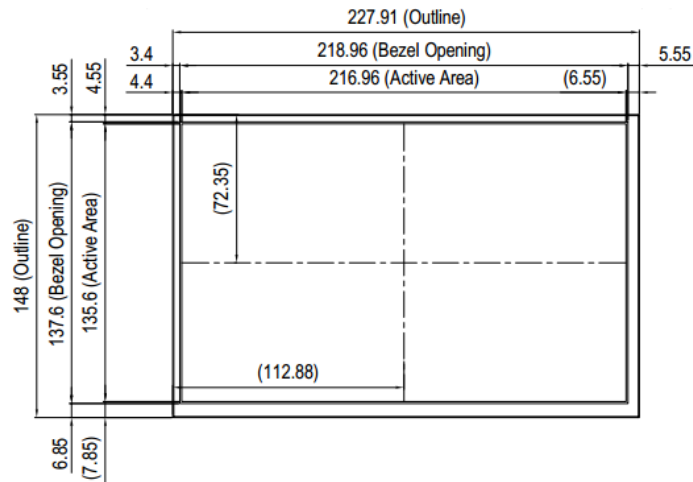
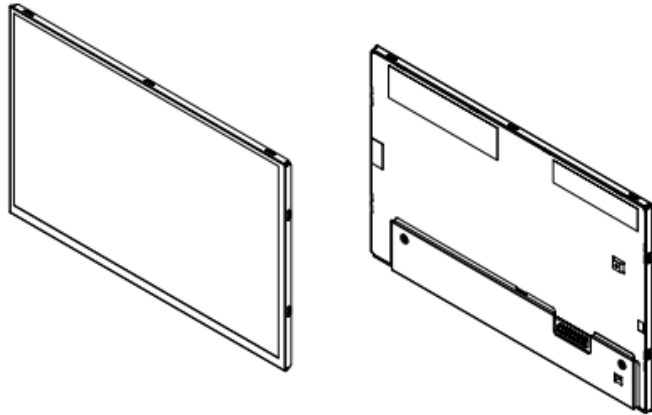



7.23 (Screw Hole For Grounding)

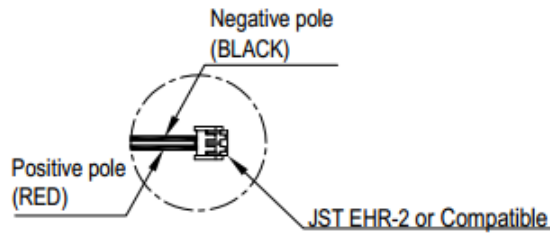
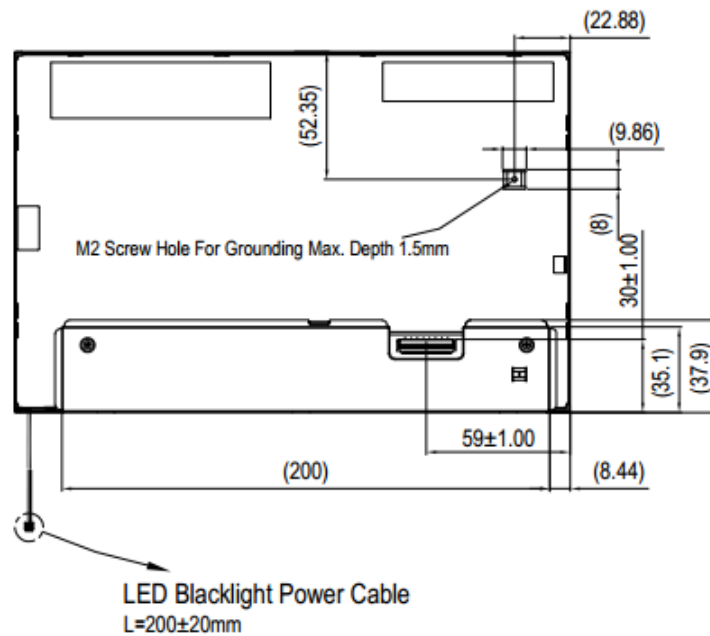
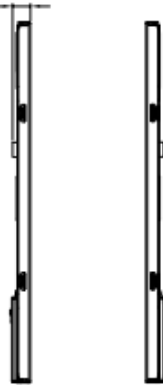

**Connector View**

Note:

1. CN1: The Interface Connector
2. Torque Of M2 User Hole Should Be Within TBD kgf-cm And Re-Screw 10 Times
3. Tolerance Is  $\pm 0.5\text{mm}$  If Not Specified



Industrial Solutions Partner!

**Ordering Information**

| Part Number     | Description  |
|-----------------|--|
| DLF1015-ANN-A01 | 10.1",1000nits,1280x800,LID10C,5in1,V1                 |
| DLH1015-ANN-Q01 | 10.1",1000nits,1280x800,LID10C,AD8891DHP,DC12V,5in1,V1 |
|                 |  |

**Optional Accessories**

| Part Number  | Description  |
|--------------|--|
| 840612051212 | ADAPTER,AC/DC,12V/5 A,60W.Power-Din-4P,CWT.G99-ABF060F-N022.Efficiency-level-6,R |
| 810618301010 | CABLE,POWER,AC,1830mm USA type   |
| 810618301090 | CABLE,POWER,AC,1830mm Europe type  |
| 810618301050 | CABLE,POWER,AC,1830mm UK type  |
| 810618301170 | CABLE,POWER,AC,1830mm Australia type   |
| 810618301031 | CABLE,POWER,AC,1830mm Japan type   |
|              |  |

**Customer request**

|       |                                       |
|-------|---------------------------------------|
| Touch | SCT (Single-Touch), PCT (Multi-Touch) |
| Glass | Tempered glass,AR coating,.....       |
|       |                                       |

## Assured Systems

Assured Systems is a leading technology company with over 1,500 regular clients in 80 countries, deploying over 85,000 systems to a diverse customer base in 12 years of business. We offer high-quality and innovative rugged computing, display, networking and data collection solutions to the embedded, industrial, and digital-out-of-home market sectors.

### US

[sales@assured-systems.com](mailto:sales@assured-systems.com)

Sales: +1 347 719 4508  
Support: +1 347 719 4508

1309 Coffeen Ave  
Ste 1200  
Sheridan  
WY 82801  
USA

### EMEA

[sales@assured-systems.com](mailto:sales@assured-systems.com)

Sales: +44 (0)1785 879 050  
Support: +44 (0)1785 879 050

Unit A5 Douglas Park  
Stone Business Park  
Stone  
ST15 0YJ  
United Kingdom

VAT Number: 120 9546 28  
Business Registration Number: 07699660