

W22L100-MLA3FP

21.5" PCAP Rack Mount Defence Display



KEY FEATURES

- 21.5", 1920 x 1080 resolution
- PCAP multi-touch screen
- Compliant MIL-STD 810G/ MIL-STD 461E
- Rack mount mechanical design, supports VESA mount
- Defence-grade power connector (MIL-DTL-38999/1)
- AC 100~240V, Universal, ±10%; DC 9~36V, ±10% (Optional)
- Convenient on-screen display controls



SPECIFICATIONS

Display			
Resolution	1920x1080	Size	21.5 inches
Contrast Ratio	3000:1	Panel Brightness	250 nits
Display Color	16.7M Colors	View Angles	89,89,89,89
Active Area	476.64x268.11 mm	Touch / Glass	Projected Capacitive Multi Touch Screen PCAP with With ITO Flim (Optional)
Environment			
Operating Humidity	10% to 95% RH	Operating Temperature	0~50°C
Storage Temperature	-10°C~60°C		
Compliance			
MIL-STD 461E/F	RE101 / RE102 CE101 / CE102 with EMI Glass / Touch(Optional) RS101 / RS 103 CS101 / CS 106 / CS 109 / CS 114 / CS 115 / CS 116	MIL-STD 810F/G	Vibration Method 514.5 Humidity Method 507.4 Transit Drop Method 516.5
Certification			
Certification	CE, FCC		
IO Ports			
USB Port	1 x USB for Touch	Video	1 x VGA 5 x BNC (R,G,B,H,V) 1 x DVI-D
Mechanical			
Dimension	580 x 384 x 71 mm	Mounting	Rack Mount/ VESA Mount
Enclosure	Metal Housing with Aluminum Bezel	Cooling System	Fanless Design
Accessory			
Accessory	1 x User Manual(Hardcopy) 1 x Power Cord MIL-DTL-38999/1 1 x VGA Cable 1 x DVI Cable 1 x VGA to 5 BNC Shielding Cable		

Power	
Power Rating	AC 100~240V, Universal, ±10% DC 9~36V, ±10% (Optional)
Control	
Button	7 key: Power Decrease Increase Exit/ Auto Menu Day/ Night Lock/ Unlock

DIMENSIONS UNIT:MM

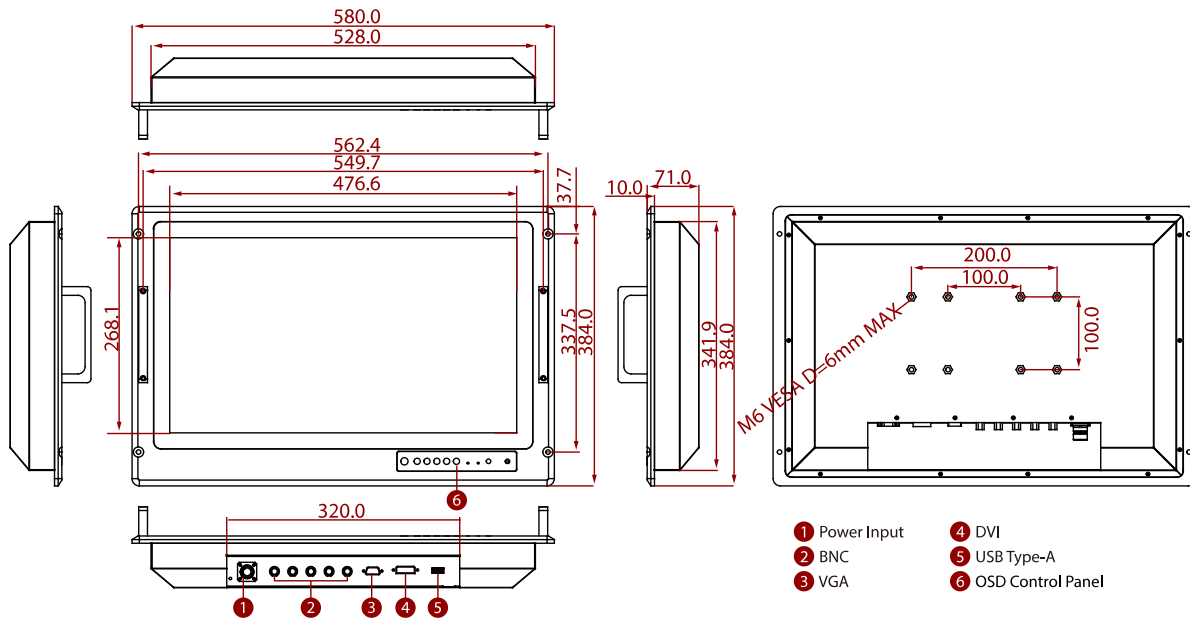

NOTE

1. This is a simplified drawing and some components are not marked in detail.
2. If you require an external test report, Winmate will charge an NRE fee.
3. Please contact our sales representative if you need further product information.
4. All specifications are subject to change without prior notice.
5. The product shown in this datasheet is a standard model. For diagrams that contain customized or optional I/O, please contact the Winmate Sales Team for more information.

Assured Systems

Assured Systems is a leading technology company with over 1,500 regular clients in 80 countries, deploying over 85,000 systems to a diverse customer base in 12 years of business. We offer high-quality and innovative rugged computing, display, networking and data collection solutions to the embedded, industrial, and digital-out-of-home market sectors.

US

sales@assured-systems.com

Sales: +1 347 719 4508
Support: +1 347 719 4508

1309 Coffeen Ave
Ste 1200
Sheridan
WY 82801
USA

EMEA

sales@assured-systems.com

Sales: +44 (0)1785 879 050
Support: +44 (0)1785 879 050

Unit A5 Douglas Park
Stone Business Park
Stone
ST15 0YJ
United Kingdom

VAT Number: 120 9546 28
Business Registration Number: 07699660