

G-WIN[®]

Military Grade

Military Display

R15L100-MLC3HB

Feature:

- High Quality 15" Panel, 1024 x 768 resolution, 800 nits
- Aluminum Housing with Anti-Corrosion Treatments
- Military Grade connector with VESA mount.
- MIL-STD-810F/G
- Built-in Ambient Light sensor

Option feature:

- 5 Wire Resistive Touch/ Anti-Reflective Protection Glass
- Wide Range 9 to 36V DC Input Acceptable
- Customized Military Connector type
- MIL-STD-461E/F (By Request)
- EMI Glass/Touch (By Request)



G-WIN



R15L100-MLC3HB

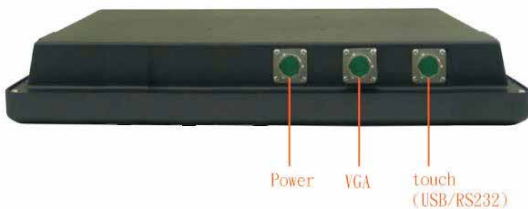

Test item	R15L100-MLC3HB
MIL-STD-810F/G *Vibration	✓
MIL-STD-810F/G *Shock	✓
MIL-STD-810F/G Humidity	✓
MIL-STD-810F/G Drop(Package)	✓

* If you require external test report, Winmate will charge NRE fee.

Drawing w/ Mounting Bracket

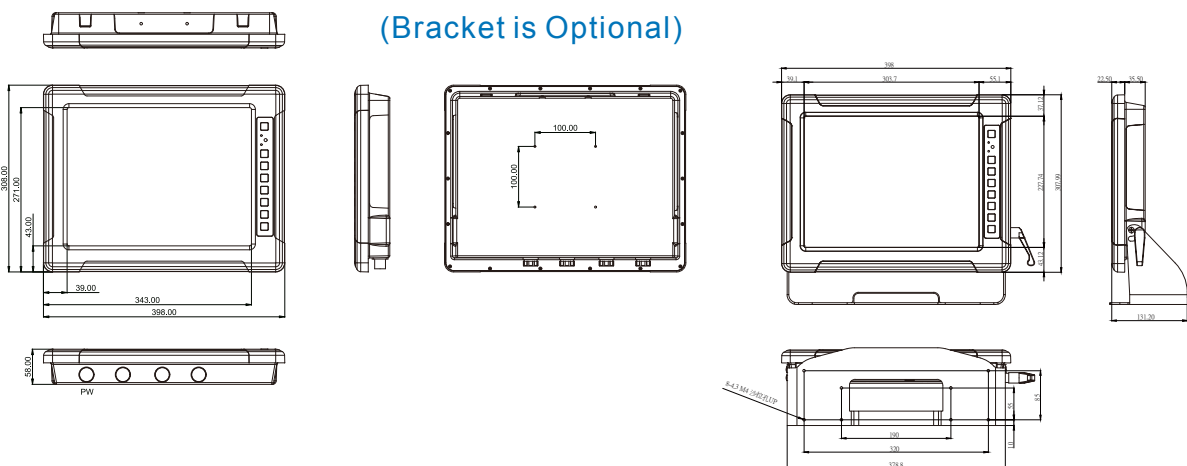

G-WIN[®]

Military Grade Military Display

R15L100-MLC3HB

Display Specification

Size : 15 inch
Resolution : 1024x768 pixels
Brightness : 800 (cd/m)
Touch : 5 Wire Resistive (Optional)
Glass : AR Glass (Default)

Mechanical and Environment

Dimensions (W x L x H) : 398 mm x 308 mm x 58mm
Operation Temperature : -20°C~70°C
Storage Temperature : -30°C~70°C
Operation Humidity : 10% to 95% (non condensing)
Shock* : Operating:40g for 11ms
Vibration* : Operating: 1.62/2.02/2.20g rms for XYZ / 5-500Hz

In Front Control

Control button : Power On/ Off, Menu,Auto, Brightness up& down, LED adjustment

LED indicator : Power Status, Sleep status

Environmental(MIL-STD 810F/G Compliance)

Vibration : MIL-STD-810F/G Method 514.5
Humidity : MIL-STD-810F/G Method 507.4
Transit Drop : MIL-STD-810F/G Method 516.5

Environmental(MIL-STD 461E/F Compliance)

RE : RE 101 / RE 102
CE : CE 101 / CE 102
Optional with EMI Glass / Touch
RS : RS 101 / RS 103
CS : CS 101 / CS 106 / CS 109 / CS 114
CS 115 / Cs116

◇◇ I/O Spec

Spec	R15L100-MLC3HB
Connector type	Mil Circular type
VGA	JY27466T11F35PN
USB/RS232	JY27466T11F35PN
Power (9~36V DC)	JY27466T09F98PN
Wide Voltage	9~36V (Isolated Power)
Optional Touch	Resistive
AR glass	Yes(default)
EMI glass/Touch	By Request

◇◇ Environment Spec

Test Item	R15L100-MLC3HB
Dust/Water proof	IP 65 (except IO part)

◇◇ Front OSD control function:

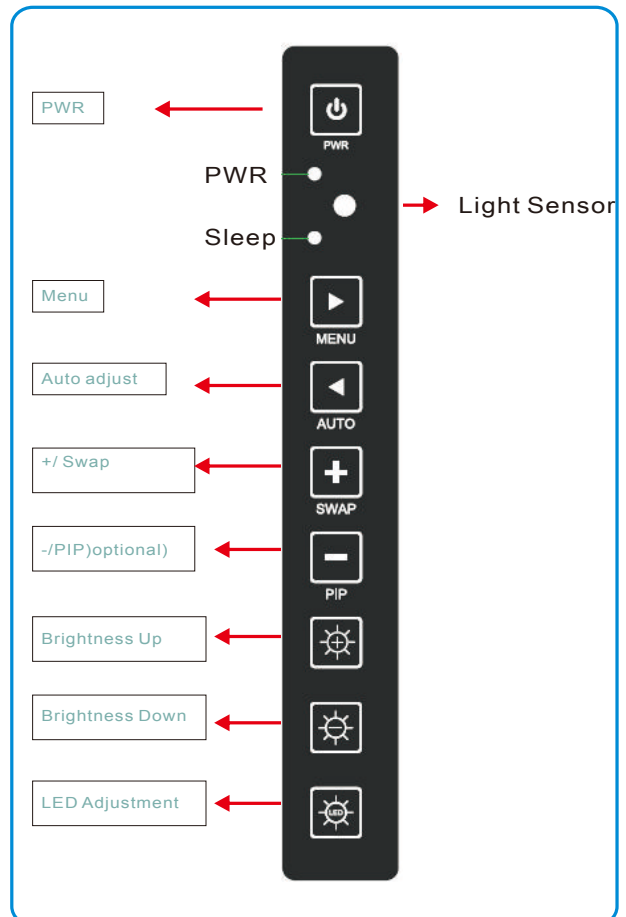

Assured Systems

Assured Systems is a leading technology company with over 1,500 regular clients in 80 countries, deploying over 85,000 systems to a diverse customer base in 12 years of business. We offer high-quality and innovative rugged computing, display, networking and data collection solutions to the embedded, industrial, and digital-out-of-home market sectors.

US

sales@assured-systems.com

Sales: +1 347 719 4508
Support: +1 347 719 4508

1309 Coffeen Ave
Ste 1200
Sheridan
WY 82801
USA

EMEA

sales@assured-systems.com

Sales: +44 (0)1785 879 050
Support: +44 (0)1785 879 050

Unit A5 Douglas Park
Stone Business Park
Stone
ST15 0YJ
United Kingdom

VAT Number: 120 9546 28
Business Registration Number: 07699660