

W24L100-MRA1HB

24" High Brightness Marine Display



KEY FEATURES

- Dimming knob control backlight brightness from nearly 0% to 100%
- High Brightness technology enhance visibility
- IP66 aluminum housing with powder coating design (IP54 rear)
- 24V DC Isolated Power Module, Marine High Brightness Display
- High quality touchscreen / AR protection glass for option
- Ease of use front panel OSD control
- Enhanced shock and vibration resistance



SPECIFICATIONS

Display			
Resolution	1920x1080	Size	24 inches
Contrast Ratio	5000:1	Panel Brightness	1000 nits
Display Color	16.7M Colors	View Angles	89,89,89,89
Active Area	531.36x298.89 mm	Touch / Glass	Resistive Touch Screen (Optional) Protection Glass w/o Touch Function (Optional)
Environment			
Operating Humidity	5% to 95%	Operating Temperature	-15~55°C
Shock	15G, 11ms duration	Vibration	0.7g@DNVGL CG-0339 (Class A)
IP rating	IP66 (Front Side)		
Certification			
Certification	CE, FCC		
IO Ports			
Serial Port	1 x RS232 for Remote Control 1 x RS232/USB for Touch Screen	Video	1 x VGA 1 x DVI-D 1 x Composite 1 x S-Video
Mechanical			
Dimension	593 x 356.7 x 62.7	Weight	9.7 kg
Mounting	VESA Mount/ Panel Mount	Enclosure	Metal Housing with Aluminum Bezel
Cooling System	Fanless Design	Cut out	566 x 362 mm
Power			
Power Rating	24V DC-in with Isolation (Approval by Certificate) 9~36V DC Input Acceptable	Consumption	55W (Typical)
Accessory			
Accessory	1 x User Manual. 1 x CD for Touchscreen Driver Tools. 1 x DVI Cable. 1 x VGA Cable. 1 x RS232 Serial Cable. 1 x S-Video Cable. 1 x Composite Cable.		

Control

Button 8 key:
Esc/PIP
Auto adjustment
Left
Right/Source
OK/Menu
Up
Down
Power
1 x The Dimming Knob

DIMENSIONS UNIT:MM

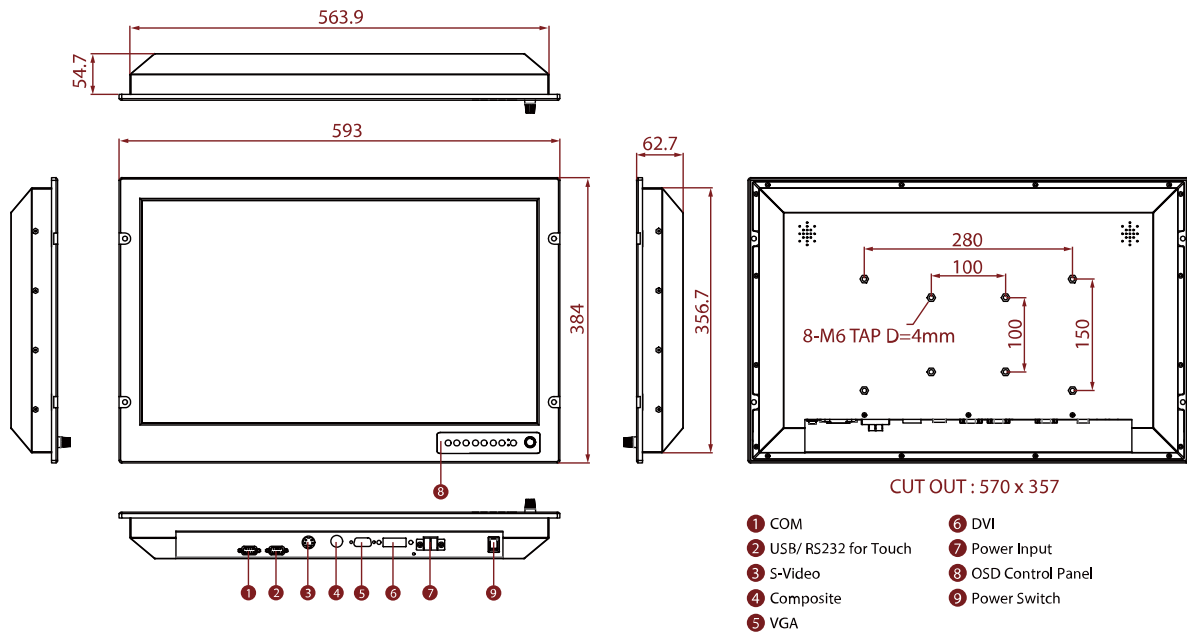

NOTE

1. This is a simplified drawing and some components are not marked in detail.
2. Please contact our sales representative if you need further product information.
3. All specifications are subject to change without prior notice.
4. The product shown in this datasheet is a standard model. For diagrams that contain customized or optional I/O, please contact the Winmate Sales Team for more information.

Assured Systems

Assured Systems is a leading technology company with over 1,500 regular clients in 80 countries, deploying over 85,000 systems to a diverse customer base in 12 years of business. We offer high-quality and innovative rugged computing, display, networking and data collection solutions to the embedded, industrial, and digital-out-of-home market sectors.

US

sales@assured-systems.com

Sales: +1 347 719 4508
Support: +1 347 719 4508

1309 Coffeen Ave
Ste 1200
Sheridan
WY 82801
USA

EMEA

sales@assured-systems.com

Sales: +44 (0)1785 879 050
Support: +44 (0)1785 879 050

Unit A5 Douglas Park
Stone Business Park
Stone
ST15 0YJ
United Kingdom

VAT Number: 120 9546 28
Business Registration Number: 07699660