



SM-151C

Industrial monitor, 15.6" True-Flat Industrial Grade 10 Points Projected Capacitive Touch



Features

- 15.6 inches FHD LCD Panel with LED backlight, front panel support IP66
- Aluminum alloy structure makes it lighter, more stable, and better heat dissipation
- Industrial grade 10-point P-cap multi-touch
- 12V DC-IN, lockable phoenix connector
- Support standard VESA(75x75mm), Panel-mount and Wall-Mount



HDMI



-10~60°C

LCD Display

Size/Type	15.6 inches FHD LCD Panel with LED backlight
Max. Resolution	1920(H) x 1080(V)
Ratio	16:9
Luminance	350 cd/m ²
Contrast Ratio	800:1
Backlight	LED Backlight
Backlight Lifetime	50000Hrs
Touch Screen	P-cap Multi-Touch
Touch	35,000,000 times
View Angle (H/V)	CR ≥ 10; 178° / 178°

Power System

Power Input	12V DC-IN by 2-pin Phoenix connector
-------------	--------------------------------------

Qualification

Certification	CE, FCC
---------------	---------

External I/O

USB Ports	1 x USB for Touch
Video Input Ports	1 x HDMI 1 x VGA 1 x DVI

Mechanical

Mounting Type	Panel Mount, Wall and VESA-mount (75 x 75 mm)
Chassis	Aluminum for front panel and heat-sink, SECC for rear cover
Dimension (W x H x D)	395 x 245.5 x 44 mm
Cut out	387 x 237.5 mm
Weight	3.05 Kg
Ingress Protection	Front panel IP66

OSD Menu

ON / OFF	Power On/Off
MENU	Menu / Confirm
Auto	Signal input switch / Quit
+	Up / Increase
-	Down / Decrease

Environmental

Operating Temp.	-10 ~ 60°C
Storage Temp.	-40 ~ 70°C
Operating Humidity	5 ~ 95% (non-condensing)
Random Vibration	5 ~ 500Hz, 2Grms operation
Sine Vibration	5 ~ 500Hz, 2G Non-operation
Shock	10g 11ms operation, 30g 11ms Non-operation

Industrial Automation System

All specifications are subject to change without notice.



Dimension

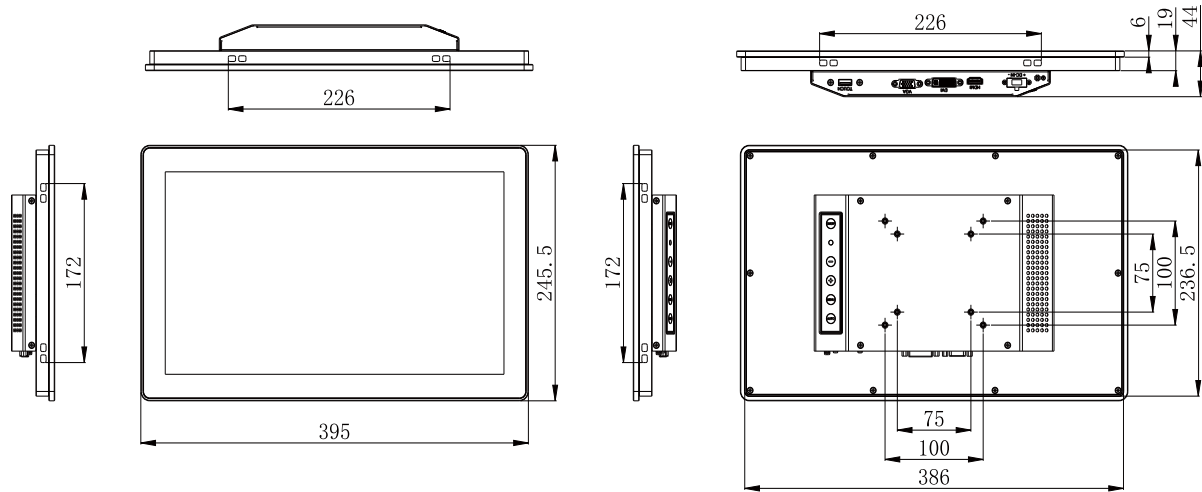

Unit: mm

Ordering Information

SM-151C 15.6" Industrial Monitor with P-Cap multi-touch



Standard Accessory

Panel Hook (4 pcs in 1 Package)

2-pin DC-in Phoenix connector

1 x VGA Cable

1 x USB Cable

Optional Accessory

PAC-60W-FSP-SPA R1.0 AC/DC Adapter KIT (w/ UKCA), 12V, 60W, 2 WIRE w/ USA POWER CORD

PAC-60W-FSP-SPA R1.1 AC/DC Adapter KIT (w/ UKCA), 12V, 60W, 2 WIRE w/ EU POWER CORD

PAC-60W-FSP-SPA R1.2 AC/DC Adapter KIT (w/ UKCA), 12V, 60W, 2 WIRE w/ UK POWER CORD

PAC-60W-FSP-SPA R1.3 AC/DC Adapter KIT (w/ UKCA), 12V, 60W, 2 WIRE w/ IN POWER CORD

Assured Systems

Assured Systems is a leading technology company with over 1,500 regular clients in 80 countries, deploying over 85,000 systems to a diverse customer base in 12 years of business. We offer high-quality and innovative rugged computing, display, networking and data collection solutions to the embedded, industrial, and digital-out-of-home market sectors.

US

sales@assured-systems.com

Sales: +1 347 719 4508
Support: +1 347 719 4508

1309 Coffeen Ave
Ste 1200
Sheridan
WY 82801
USA

EMEA

sales@assured-systems.com

Sales: +44 (0)1785 879 050
Support: +44 (0)1785 879 050

Unit A5 Douglas Park
Stone Business Park
Stone
ST15 0YJ
United Kingdom

VAT Number: 120 9546 28
Business Registration Number: 07699660