

# M101RK 10.1-inch Rugged Tablet PC

ARM-based

A Rugged Tablet that Can Survive Any Environment and Get Real Work Done

M101RK is a rugged tablet PC with a robust set of features designed to withstand industrial use while providing high tech solutions that increase productivity, improve safety, and reduce operational costs. The processing power comes from a Dual-core Cortex-A72 + Quad-core Cortex-A53 processor for high performance. The tablet features a brilliant in-plane switching with direct optical bonding projected capacitive touch screen, which is sunlight readable and offers a 1920 x 1200 pixel resolution. Weighing at just 2.2 pounds (990 grams), the M101RK delivers lightweight mobility in a rugged tablet.



## Highlights

- High performance Dual-core Cortex-A72 up to 2.0GHz + Quad-core Cortex-A53 up to 1.5GHz
- 10.1" 1920x1200 LED Panel with P-Cap Touch
- Android 7.1
- IP65 water and dust proof
- Dual Camera Design: 8MP Main camera with LED flash / 2MP Webcam
- MIL-STD-810G Shock / Drop / Vibration Compliant
- Optional Barcode Reader and NFC Reader

Order Information			
	LTE	1D/2D Barcode Reader	NFC Reader
M101RK	N/A	N/A	Optional
M101RK-BM	N/A	Default	Optional
M101RK-4E	Default	N/A	Optional
M101RK-4EBM	Default	Default	Optional

## NFC Tag Support

Support Card Type (13.56 MHz)	
NFC Forum Platform	Type 1, Type 2, Type 3, Type 4
ISO 15693	TI HF-I Plus, TI HF-I Pro, NXP-Code SLI
ISO 14443-A	NXP Mifare_One(S50_4byte), NXP Mifare_One(S50_7byte), NXP Mifare_One(S70_4byte), NXP Mifare_UltraLight, NXP Mifare_UltraLight C, NXP Mifare_DesFire_EV1, NXP Mifare_Plus S/X
ISO 14443-B	Infineon JTOP
ISO 18092(R/W)	SONY Felica Lite s, SONY Felica Lite

# M101RK 10.1-inch Rugged Tablet PC

ARM-based

A Rugged Tablet that Can Survive Any Environment and Get Real Work Done

## Display Specification

Size	10.1-inch IPS display with LED Backlight
Resolution	1920 x 1200
Brightness	800 nit With Optical Bonding for Sunlight Readability
Touch	Multi-Touch Projected Capacitive
Contrast Ratio	800:1
Viewing Angle Technology	85/85/85/85 <ul style="list-style-type: none"> <li>• Anti reflective and anti-glare technology (Optional)</li> <li>• Automatic screen rotation</li> </ul>
Sensors	Light Sensor / G-Sensor / Gyroscope / E-Compass

## System Specification

Processor	Dual-core Cortex-A72 up to 2.0GHz + Quad-core Cortex-A53 up to 1.5GHz
System Memory	2GB <sup>1</sup>
Storage	16GB eMMC
Operating System	Android 7.1

## Wireless Communication

WLAN	802.11 a/b/g/n/ac
Bluetooth	Bluetooth 4.2
GPS	Supports GPS
WWAN	Optional 4G/LTE or 3G

## Interface

Docking Connector	1 x 19-pin docking connector
HDMI	1 x Micro HDMI
USB	1 x USB 3.0 Type C (OTG) 1 x USB 3.0 Type A
Power Input	1 x Power Jack
Micro SD	1 x Micro SD Slot
Audio Connector	1 x Audio Combo Conn. (Mic in / Line Out)

## Keyboard and Input

Touch	• P-Cap multi-touch
Button	1 x Power, 1 x Home, 1 x Back, 1 x Menu, 1 x Volume Up, 1 x Volume Down
LED Indicators	1 x Status Indicator

## Audio

Microphone	1 x Built-in Mic
Speaker	2 x Built-in 1W Speaker

## Cameras

Web Camera	2 MP Camera with built-in microphone
Rear Camera	8MP Auto-Focus Camera with LED Flash

## Data Capture

Barcode	Optional 1D/2D Barcode Reader
NFC	Optional NFC Reader

## Security Function

Security Function	Kensington Lock
-------------------	-----------------

## Mechanical and Environment

Dimension (W x L x H)	271.8 x 197.2 x 19 mm (10.7 x 7.76 x 0.75 inches) <sup>2</sup>
Weight	990 grams (2.18 lbs)
Operating Temperature	AC Mode -20°C to 60°C (-4°F to 140°F) Battery mode -10°C to 50°C (14°F to 122°F)
Storage Temperature	-20°C to 60°C (-4°F to 140°F)
Humidity	10% to 90% RH, non-condensing
IP Proof	IP65
Shock	MIL-STD-810G Method 516.6 Procedure I
Vibration	MIL-STD-810G Method 514.6 Procedure I
Drop	MIL-STD-810G Method 516.6 Procedure I, 4 ft to concrete <sup>3</sup>

## Power Management

Power Input	19V DC in
Battery	7.4V, typ. 5140 mAh Li-Polymer Battery (2S1P)
Battery Operating Time	Standard Battery: 8 hours <sup>4</sup>
Adapter	110-240 AC to 19V DC out Power Adapter

## Accessories

### Standard Accessories

Adapter and Power Cord	922D065W19V1
Standard Battery	98K000A0003T
Capacitive Stylus	9B000000001D

### Optional Accessories <sup>5</sup>

Desk Dock	98K000A00052
Vehicle Dock (without VGA output)	98K000A00051
Vehicle Cradle	98TA10Z00005
Battery Charger	98KT00A0000F
Hand Strap	98K000A0003J
VESA Mount Kit	98KT00A0001H
Shoulder Strap	98K000A0003Q
Carry Bag	9B000000003J
Vehicle Charger	9226065W19V0

## Drawing <sup>6</sup>

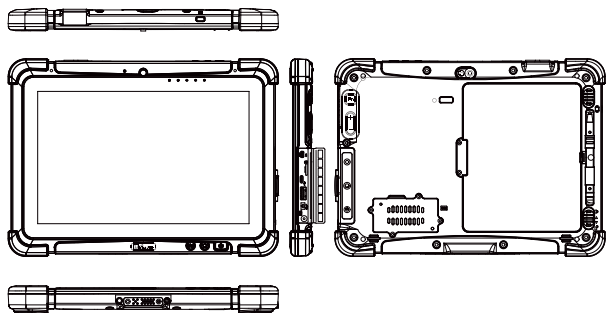

Do Not Expose the Battery Pack to Excessive Heat, or Extreme Heat (Near Fire, in Direct Sunlight for example)  
Do not expose bare skin to this product when handling this unit in extreme hot or cold environments

- Caution**
1. Total usable memory will be less depending upon actual system configuration.
  2. Length measurements do not include protrusions. Weight varies with options.
  3. The drop test with high-capacity battery must come with hand strap.
  4. Measured at dimming LCD brightness. Varies depending on the usage conditions, or when an external device is attached.
  5. Accessories may vary depending on your configuration.
  6. This is a simplified drawing and some components are not marked in detail.

## Assured Systems

Assured Systems is a leading technology company with over 1,500 regular clients in 80 countries, deploying over 85,000 systems to a diverse customer base in 12 years of business. We offer high-quality and innovative rugged computing, display, networking and data collection solutions to the embedded, industrial, and digital-out-of-home market sectors.

### US

[sales@assured-systems.com](mailto:sales@assured-systems.com)

Sales: +1 347 719 4508  
Support: +1 347 719 4508

1309 Coffeen Ave  
Ste 1200  
Sheridan  
WY 82801  
USA

### EMEA

[sales@assured-systems.com](mailto:sales@assured-systems.com)

Sales: +44 (0)1785 879 050  
Support: +44 (0)1785 879 050

Unit A5 Douglas Park  
Stone Business Park  
Stone  
ST15 0YJ  
United Kingdom

VAT Number: 120 9546 28  
Business Registration Number: 07699660