



R15IT3S-67C3(HB)

15" Intel® Core™ i5-1135G7 G-WIN Full IP67 Panel PC



KEY FEATURES

- 11th Generation (Tiger Lake) Intel® Core™ i5-1135G7 2.4GHz (turbo to 4.2GHz)
- High Quality 15" Panel, 1024 x 768 resolution, 1000 nits
- Dust/ Water proof design with VESA mount Full IP67 Panel PC
- Aluminum Die-Casting Housing with Anti-Corrosion Treatments
- Build in ambient Light sensor, Full IP67 Panel PC
- Wide Range 9 to 36V DC Input with isolation. Optional for Ignition On/Off delay
- 5 Wire Resistive Touch / Anti-Reflective Protection Glass (Optional)

INTRODUCTION

Winmate G-WIN IP67 Series Panel PC offers robust performance and versatility for demanding industrial environments. Available in sizes from 7" to 21.5", these fully sealed panel PCs feature IP67-rated water and dustproof protection, ensuring reliability in harsh conditions. Designed with a P-cap multi-touch screen, optical bonding, and optional anti-reflective glass, they deliver exceptional clarity and usability. The anti-corrosion aluminum die-cast housing, wide operating temperature range, and support for various OS make this series ideal for outdoor, manufacturing, and vehicle-mounted applications.

OVERVIEW



An actual flat, easy-to-clean front surface with an edge-to-edge design

Winmate's Flat aluminum P-Cap panel PCs and display go beyond standard industrial panel computers with an elegant, edge-to-edge design. Easy to maintain and clean to prevent water or liquid droplets penetrates every opening in the device.

Full IP67 Protection against water and dust

Winmate G-WIN IP67 panel PC is dust and waterproof, and ideal for harsh environments.



No. 18, Zhongxing S. St., Sanchong Dist., New Taipei City 241017, Taiwan (R.O.C.)
Tel: +886-2-8511-0288
Website: www.winmate.com

Revised: V.240507.241125



Fanless cooling system and ultra-low power consumption

G-WIN series adopts a fanless design with passive cooling fins. Reduce noise, and power consumption, boost reliability, and extend the life cycle.

Comprehensive IO Ports

Winmate offers rugged and reliable industrial computing solutions. To meet various industrial applications, Winmate Panel PCs offer various IO interfaces.



Rugged housing with anti-shock and vibration

Winmate's G-WIN series panel PCs are designed and pass the US Defence standards environment tests. The overall construction of the G-WIN panel is inherently rugged with the aluminum die-cast housing and anti-corrosion to hold up even in exposed settings.

SPECIFICATIONS

System Specification

WLAN	Support (Optional)	BT	Support (Optional)
Processor	Intel Core i5-1135G7 2.4GHz (up to 4.2GHz)	Memory	1 x SO-DIMM, DDR4 3200 MHz, 4GB 8GB (Optional) 16GB (Optional) 32GB (Optional)
Storage	1 x M.2 2280 M-Key NVMe SSD 128GB 256GB (Optional) 512GB (Optional) 1TB (Optional) 2TB (Optional)	Ethernet controller	1 x Intel® Ethernet Controller
Security	TPM 2.0	Operating System	Windows 11 IoT Enterprise (64 bit) (Optional) Windows 11 Pro 64 bit (Optional) Linux Ubuntu 22.04(Do not support Wake on Touch) (Optional)

Display

Resolution	1024x768	Size	15.0 inches
Contrast Ratio	2000:1	Panel Brightness	1000.0 nits
View Angles	88,88,88,88	Active Area	304.1x228.1 mm
Touch / Glass	Resistive Touch Screen Bonding With Panel Protection Glass Without touch function (Optional)		

Mechanical

Dimension	398 x 308 x 58 mm	Weight	4.2 kg
Mounting	VESA Mount Yoke Mount	Enclosure	Aluminum Housing
Cooling System	Fanless design		

Environment

Operating Humidity	10% to 90% RH, Non-Condensing	Operating Temperature	-10°C to 55°C -40°C to 70°C (with intelligent heater)
Storage Temperature	-30°C to 70°C	Shock	MIL-STD-810G Method 516.6 Procedure I
Vibration	MIL-STD-810G Method 514.6 Procedure I	IP rating	IP67

Certification

Certification	CE, FCC
----------------------	---------

IO Ports

Power Input	1 x M12 waterproof connector for 9~36V DC	USB Port	1 x M12 waterproof connector for 2 x USB2.0
Serial Port	1 x M12 waterproof connector for RS232	LAN	1 x waterproof Giga LAN RJ45 connector
Indicator	1 x LED Indicator for power 1 x LED Indicator for storage		

Control

Button	1 x "Power" key to power on the device. 1 x "+" key to increase screen brightness. 1 x "-" key to decrease screen brightness. 1 x "Menu" key can Automatically or manually adjusts brightness of the display screen 1 x Day / Night Mode button 1 x LED indicator brightness adjustment button
---------------	---------------------------------------------------------------------------------------------------------------------------------------------------------------------------------------------------------------------------------------------------------------------------------------------------------------





1 x Ambient Light sensor

Accessory

Accessory

External open wire Power cable with waterproof connector
 External USB cable with waterproof connector
 External COM cable with waterproof connector
 External LAN cable with waterproof connector
 Waterproof caps
 RJ45 female-female converter
 VESA screws

Optional Accessory

Yoke mount stand (Optional)
 100~240V AC to DC 120W Adapter with power cord (Optional)

DIMENSIONS UNIT:MM

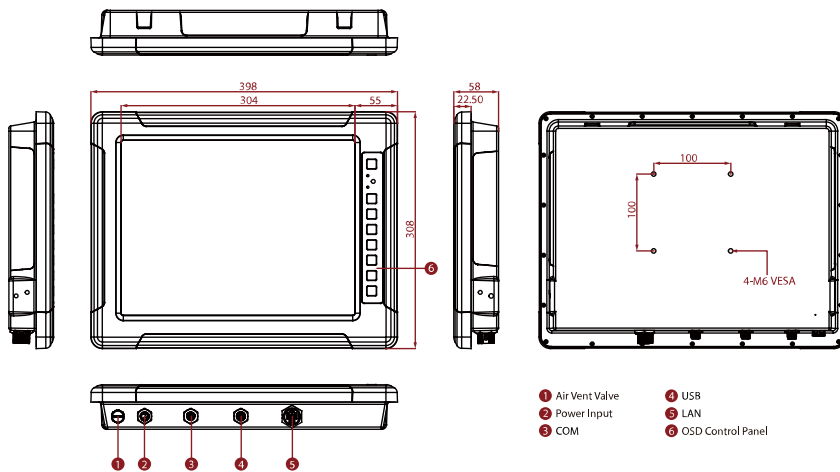

- 1 Air Vent Valve
- 2 Power Input
- 3 COM
- 4 USB
- 5 LAN
- 6 OSD Control Panel

NOTE

1. This is a simplified drawing and some components are not marked in detail.
2. Weight of the device varies by configuration.
3. Please contact our sales representative if you need further product information.
4. All specifications are subject to change without prior notice.
5. The product shown in this datasheet is a standard model. For diagrams that contain customized or optional I/O, please contact the Winmate Sales Team for more information.

Assured Systems

Assured Systems is a leading technology company with over 1,500 regular clients in 80 countries, deploying over 85,000 systems to a diverse customer base in 12 years of business. We offer high-quality and innovative rugged computing, display, networking and data collection solutions to the embedded, industrial, and digital-out-of-home market sectors.

US

sales@assured-systems.com

Sales: +1 347 719 4508
Support: +1 347 719 4508

1309 Coffeen Ave
Ste 1200
Sheridan
WY 82801
USA

EMEA

sales@assured-systems.com

Sales: +44 (0)1785 879 050
Support: +44 (0)1785 879 050

Unit A5 Douglas Park
Stone Business Park
Stone
ST15 0YJ
United Kingdom

VAT Number: 120 9546 28
Business Registration Number: 07699660