

# W07L100-PCT1

## 7" Multi-Touch Chassis Display



### KEY FEATURES

- 7" 1024 x 600 Resolution, Multi-Touch Chassis Display
- Projected Capacitive Multi-Touch (P-Cap)
- Front IP65 Water and Dust Proof
- VGA input and variety of optional connectors
- USB port for touch
- Stylish and elegant design



### SPECIFICATIONS

Display			
<b>Resolution</b>	1024x600	<b>Size</b>	7.0 inches
<b>Contrast Ratio</b>	1000:1	<b>Panel Brightness</b>	320.0 nits
<b>Display Color</b>	16.7M Colors	<b>View Angles</b>	75,75,75,70
<b>Active Area</b>	153.6x90 mm	<b>Touch / Glass</b>	Projected Capacitive Multi Touch Screen
Environment			
<b>Operating Humidity</b>	10% to 90% RH, Non-Condensing	<b>Operating Temperature</b>	0°C to 50°C
<b>Storage Temperature</b>	-10°C to 60°C		
Certification			
<b>Certification</b>	CE, FCC		
IO Ports			
<b>USB Port</b>	1 x USB for Touch Screen	<b>Video</b>	1 x VGA 1 x HDMI (Optional) 1 x DVI (Optional)
<b>Audio</b>	1 x Speaker (Optional)		
Mechanical			
<b>Dimension</b>	189.4 x 145.4 x 39.8 mm	<b>Weight</b>	0.68 kg
<b>Mounting</b>	VESA Mount	<b>Enclosure</b>	Metal
<b>Cooling System</b>	Fanless Design		
Accessory			
<b>Accessory</b>	1 x VGA cable 1 x HDMI cable 100~240V AC to DC Adapter Power Cord Manual VESA screws(Varies by product)	<b>Optional Accessory</b>	Remote Controller (Optional,Varies by product)
Power			
<b>Power Rating</b>	12V DC in		
Control			
<b>Button</b>	5 Keys: -, +, Power, Esc, Enter		

**DIMENSIONS** UNIT:MM

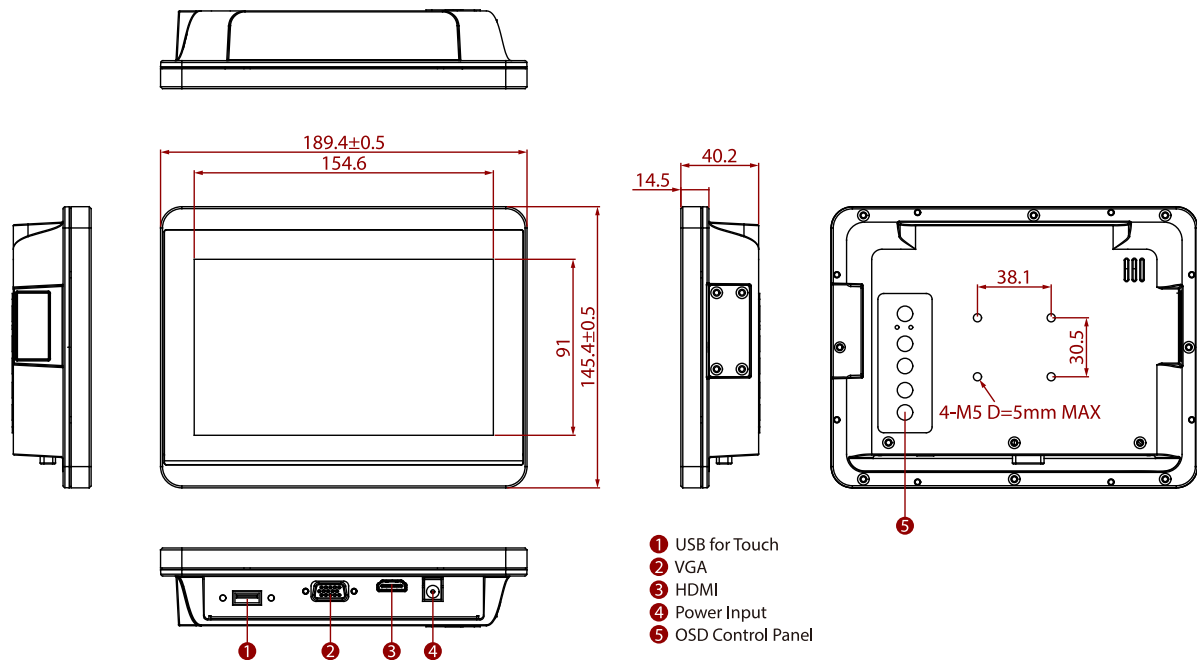

**NOTE**

1. This is a simplified drawing and some components are not marked in detail.
2. When with HDMI outside dimension and I/O will be different from standard.
3. Please contact our sales representative if you need further product information.
4. All specifications are subject to change without prior notice.
5. The product shown in this datasheet is a standard model. For diagrams that contain customized or optional I/O, please contact the Winmate Sales Team for more information.

## Assured Systems

Assured Systems is a leading technology company with over 1,500 regular clients in 80 countries, deploying over 85,000 systems to a diverse customer base in 12 years of business. We offer high-quality and innovative rugged computing, display, networking and data collection solutions to the embedded, industrial, and digital-out-of-home market sectors.

### US

[sales@assured-systems.com](mailto:sales@assured-systems.com)

Sales: +1 347 719 4508  
Support: +1 347 719 4508

1309 Coffeen Ave  
Ste 1200  
Sheridan  
WY 82801  
USA

### EMEA

[sales@assured-systems.com](mailto:sales@assured-systems.com)

Sales: +44 (0)1785 879 050  
Support: +44 (0)1785 879 050

Unit A5 Douglas Park  
Stone Business Park  
Stone  
ST15 0YJ  
United Kingdom

VAT Number: 120 9546 28  
Business Registration Number: 07699660