

VITAM-115P/R/G(H)

15" IP66 / IP69K Stainless Steel Display

Industrial Panel PC

HMI Controller

Industrial Display Monitor

Box PC



Features

- 15" New Generation Stainless Steel Display
- True Flat Front Bezel Design and Grade 304 Stainless Steel Enclosure (Grade 316 for Option)
- IP66/IP69K Rated with M12 (W.F.) Connectors
- Support Resistive Touch, Projected Capacitive Touch, and Glass
- Touch on/off Button on the Side Edge for Hygienic Cleaning
- Support Ergonomic Versatile Mounting: Yoke Mounting / Space-saving VESA 75 x 75 mm Mounting

Specifications

IO Port	
VGA	1 x M12 12-pin for VGA with waterproof cover and chain
HDMI	1 x W.F. HDMI with waterproof cap
USB	1 x M12 USB 2.0 with waterproof cover and chain
Speaker	1 x 2W IP65 speaker (option)
OSD Control Membrane	OSD on the rear side
Power Connector	1 x M12 3-pin for DC power with waterproof cover and chain

Display	Standard	High Brightness Optional
Display Type	15" TFT-LCD	15" TFT-LCD
Max. Resolution	1024 x 768	1024 x 768
Max. Color	16.2M	16.7M
Luminance (cd/m ²)	300	1000
View Angle	176(H) / 176(V)	176(H) / 176(V)
Contrast	2000:1	1000:1
Backlight Lifetime	70,000 hrs	70,000 hrs

Touch Screen	
Type	Resistive Touch (for R model) Projected Capacitive Touch (for P model) Glass (for G model)
Interface	USB
Light Transmission(%)	Resistive Touch : 80% Projected Capacitive : 90%

Power	
Power Input	DC 9~36V
Power Consumption	VITAM-115R: Max 9W VITAM-115PH: Max 17W

Mechanical	
Construction	304 Stainless steel chassis(default), 316 Stainless steel chassis(optional)
Mounting	VESA Mount 75 x 75, Yoke mount (option)
IP Rating	Total IP66/IP69K
Dimensions	399 x 324 x 53 mm
Net Weight	6.5 kg

Dimensions

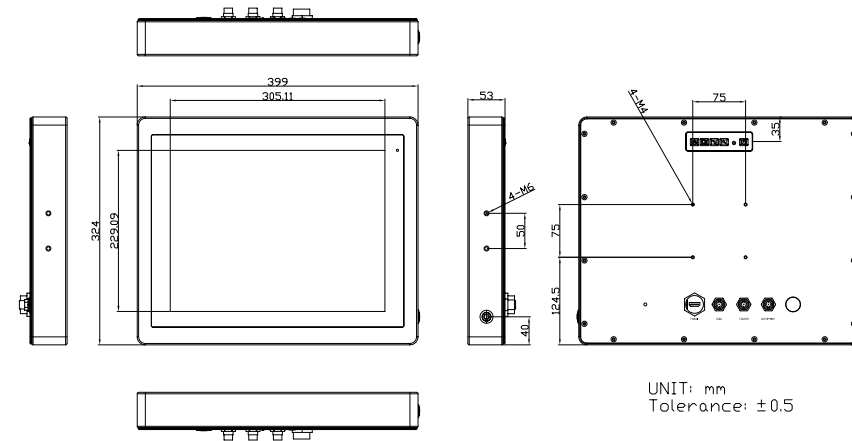

Environmental	
Operating Temperature	0~50°C / -20~60°C (option)
Storage Temperature	-30~70°C
Humidity	10 to 95% @ 40°C, non- condensing
Certificate	CE/FCC Class A

Ordering information	
VITAM-115P	15" XGA IP66/IP69K stainless steel display, VGA/HDMI input, OSD on the rear side, projected capacitive touch, 9~36V DC power input with Adapter
VITAM-115R	15" XGA IP66/IP69K stainless steel display, VGA/HDMI input, OSD on the rear side, 5 wire resistive touch window, 9~36V DC power input with Adapter
VITAM-115G	15" XGA IP66/IP69K stainless steel display, VGA/HDMI input, OSD on the rear side, protection glass, 9~36V DC power input with Adapter
VITAM-115PH	15" XGA IP66/IP69K stainless steel display, VGA/HDMI input, OSD on the rear side, projected capacitive touch, 9~36V DC power input with Adapter, 1,000 nits LCD
VITAM-115RH	15" XGA IP66/IP69K stainless steel display, VGA/HDMI input, OSD on the rear side, 5 wire resistive touch window, 9~36V DC power input with Adapter, 1,000 nits LCD
VITAM-115GH	15" XGA IP66/IP69K stainless steel display, VGA/HDMI input, OSD on the rear side, protection glass, 9~36V DC power input with Adapter, 1,000 nits LCD

Assured Systems

Assured Systems is a leading technology company with over 1,500 regular clients in 80 countries, deploying over 85,000 systems to a diverse customer base in 12 years of business. We offer high-quality and innovative rugged computing, display, networking and data collection solutions to the embedded, industrial, and digital-out-of-home market sectors.

US

sales@assured-systems.com

Sales: +1 347 719 4508
Support: +1 347 719 4508

1309 Coffeen Ave
Ste 1200
Sheridan
WY 82801
USA

EMEA

sales@assured-systems.com

Sales: +44 (0)1785 879 050
Support: +44 (0)1785 879 050

Unit A5 Douglas Park
Stone Business Park
Stone
ST15 0YJ
United Kingdom

VAT Number: 120 9546 28
Business Registration Number: 07699660