



Industrial Solutions Partner!

SSD2945-A

29.4" Resizing LCD, 1000 nits LED backlight, 1920 x 720

The SSD2945-A is a 29.4 inch color TFT-LCD display with high brightness 1000 nits and high color saturation. it produce sharp images, crisp text and lifelike colors. The Spanpixel LED backlight technology ensures high reliability and low power consumption, suitable for outdoor application, kiosk, factory automation, military, transportation and gaming application.

Key Features

- 29.4" Resizing LCD
- Ultra-Wide Screen (16 : 6)
- High Brightness 1000 nits
- LED Backlight
- Wide viewing angle 178°(H)~ 178°(V)
- Low Power Consumption
- BL MTBF: 100,000 hours



Specifications

Model Name	SSD2945-A
Description	29.4" Resizing LCD, 1000 nits LED backlight, 1920x720
Screen Size	29.4"
Display Area (mm)	698.4(H) x 261.9(V)
Brightness	1000 cd/m ²
Resolution	1920x720
Aspect Ratio	16 : 6
Contrast Ratio	5400 : 1
Pixel Pitch (mm)	0.36375(H) x 0.36375(V)
Pixel Per Inch (PPI)	70
Viewing Angle	178°(H),178°(V)
Color Saturation (NTSC)	87%
Display Colors	16.7M
Response Time (Typical)	6.5ms
Panel Interface	LVDS
Video Interface	HDMI, DP
Input Power	DC12V
Power Consumption	40W
OSD Key	4 Keys (Power Switch, Menu, +, -)
OSD Control	Brightness, Color, Contrast, Auto Turing, H/V Position...etc
Dimensions (mm)	738 x 305.2 x 61.9
Bezel Size(U/B/L/R)	24/19.3/19.8/19.8
Mounting (mm)	75x75, 400x75
Weight (Net)	6.8 kg
Operating Temperature	0 °C ~ 50 °C
Storage Temperature	-20 °C ~ 60 °C

SSD= Panel + LED Driving Board + AD Control Board + Housing

Specifications are subject to change without notice.
All brands or product names are trademarks or registered trademarks of their respective companies.



Industrial Solutions Partner!

Mechanical Drawing

Outline Dimensions

Unit: mm

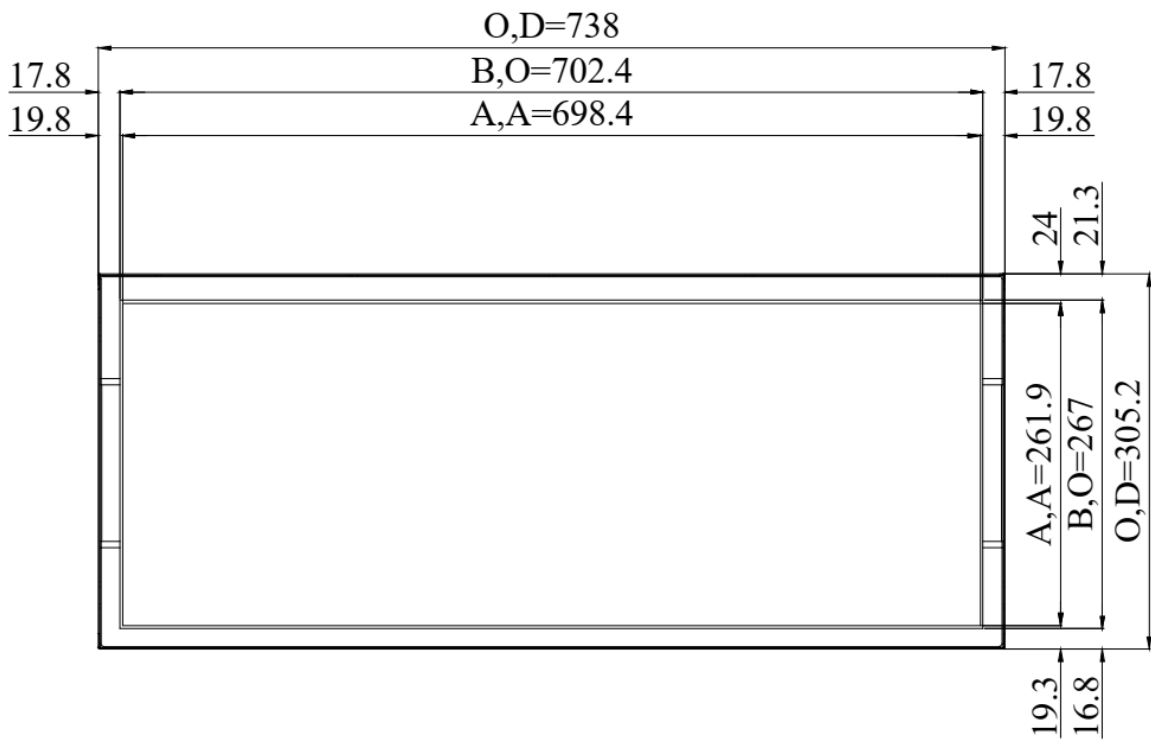
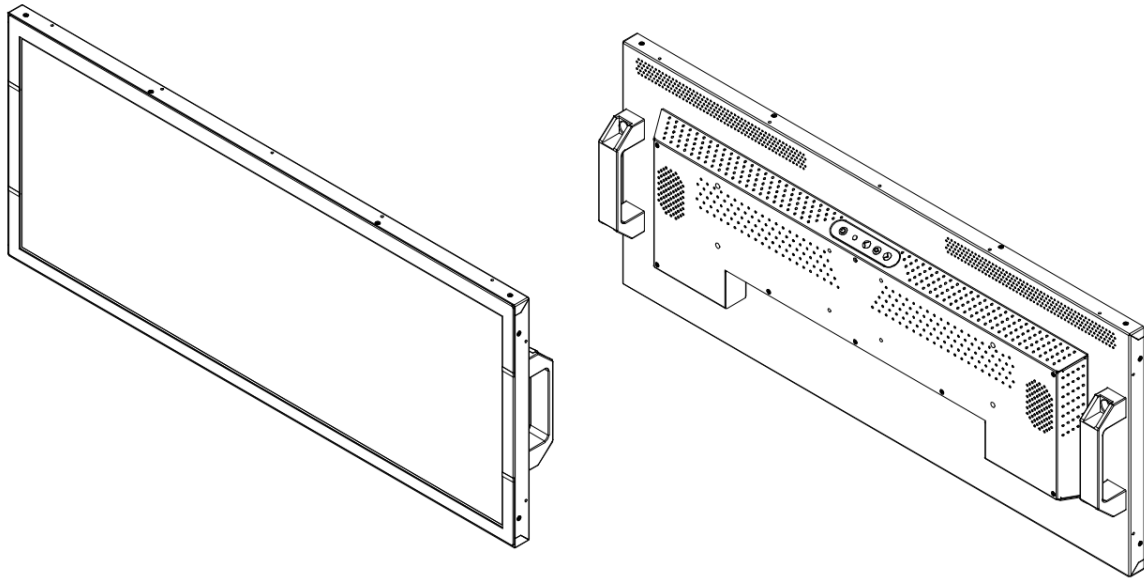

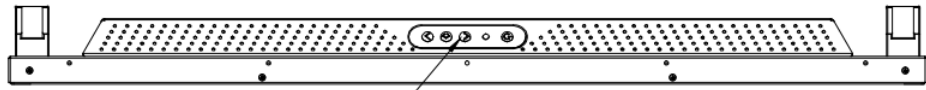

MEMBRANE 4-KEY

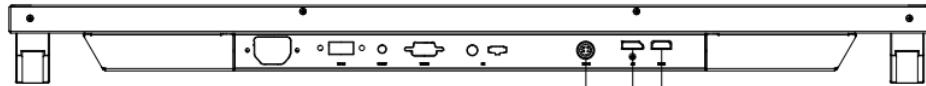

HDMI
DP
DC IN

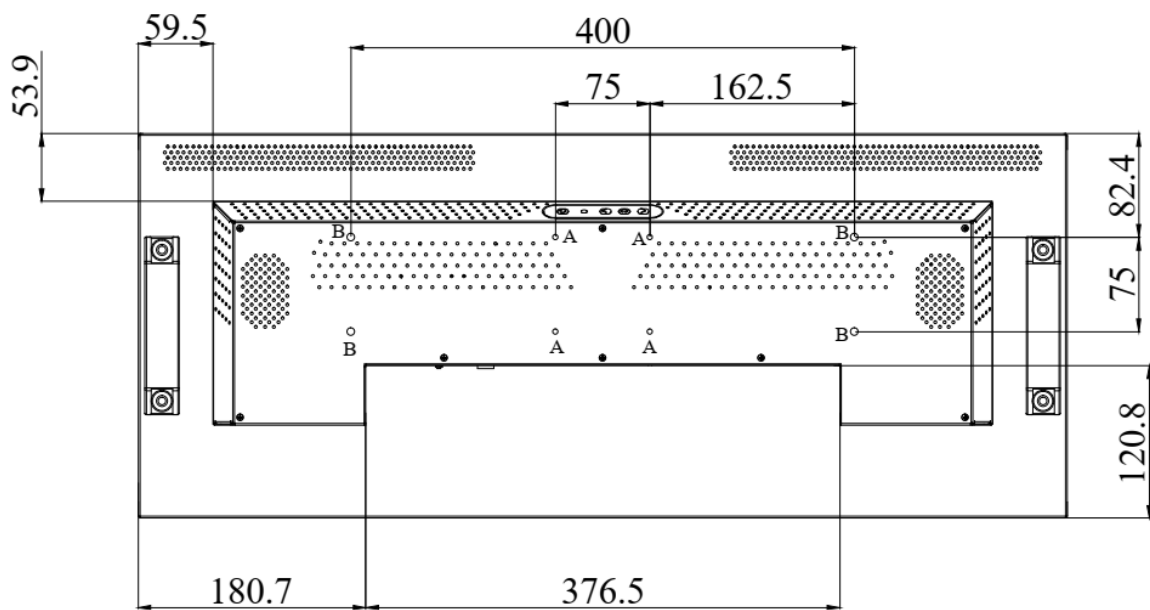
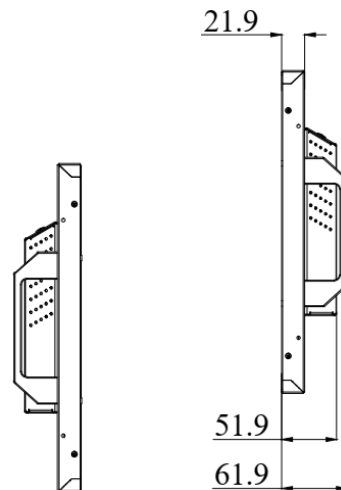



Industrial Solutions Partner!

NOTE :

- O.D. : OUTLINE DIMENSION
- B.O. : BEZEL OPENING
- A.A. : LCD ACTIVE AREA
- A : 4-M4_VESA HOLE_Max Depth=5 mm
- B : 4-M6_VESA HOLE_Max Depth=7 mm

All mechanical parts are with black painted

Ordering Information

Part Number	Description
SSD2945-ANB-T11	29.4", 1000nits, 1920x720, LID29C, AD68862HP, O/B, DC12V, 3in1, V1

Optional Accessories

Part Number	Description
840612051212	ADAPTER, AC/DC, 12V/5A, 60W, Power-Din-4P, CWT, G99-ABF060F-N022, Efficiency-level-6, R
810618301010	CABLE.POWER.AC.1830mm USA type
810618301090	CABLE, POWER, AC, 1830mm Europe type
810618301050	CABLE.POWER.AC.1830mm UK type
810618301170	CABLE.POWER.AC, 1830mm Australia type
810618301031	CABLE.POWER.AC.1830mm Japan type

By Customer Request

Glass	Tempered glass, AR coating.....
Touch	PCT, SCT, Resistive.....

Assured Systems

Assured Systems is a leading technology company with over 1,500 regular clients in 80 countries, deploying over 85,000 systems to a diverse customer base in 12 years of business. We offer high-quality and innovative rugged computing, display, networking and data collection solutions to the embedded, industrial, and digital-out-of-home market sectors.

US

sales@assured-systems.com

Sales: +1 347 719 4508
Support: +1 347 719 4508

1309 Coffeen Ave
Ste 1200
Sheridan
WY 82801
USA

EMEA

sales@assured-systems.com

Sales: +44 (0)1785 879 050
Support: +44 (0)1785 879 050

Unit A5 Douglas Park
Stone Business Park
Stone
ST15 0YJ
United Kingdom

VAT Number: 120 9546 28
Business Registration Number: 07699660