

# R10IP8M-RTT2GP

## 10.4inch Waterproof Tablet with Intel® Pentium® N4200



### KEY FEATURES

- Intel® Pentium® N4200 Apollo Lake processor waterproof tablet
- 10.4" 1024 x 768 Resolution Transflective TFT-LCD Panel
- Plastic front cover and Alu-Mg Alloy rear cover with Protective Rubber
- Trusted platform module (TPM) V2.0
- Built-in Wireless / BT / GPS
- Optional 4G LTE
- Adjustable kickstand handle (Optional)



### SPECIFICATIONS

Display	
<b>Resolution</b>	1024x768
<b>Contrast Ratio</b>	1000:1
<b>View Angles</b>	88,88,88,88
<b>Size</b>	10.4 inches
<b>Panel Brightness</b>	700.0 nits
<b>Touch / Glass</b>	Resistive Touch Screen (Optional) Protection Glass Without Touch Function (Optional)
System Specification	
<b>Processor</b>	Intel Pentium N4200 1.1GHz (up to 2.5GHz)
<b>Storage</b>	1 x M.2 2242 SSD 128GB M.2 2242 SSD up to 512GB (Optional)
<b>Security</b>	TPM 2.0
<b>WLAN</b>	Wi-Fi Support
<b>WWAN</b>	4G/ LTE or 3G (Optional)
<b>Memory</b>	1 x SO-DIMM, DDR3L 1600 MHz, 4GB 8GB (Optional)
<b>Ethernet controller</b>	2 x Intel® Ethernet Controller
<b>Operating System</b>	Windows 10 IoT Enterprise (Optional) Linux Ubuntu 20.04 (Optional)
<b>BT</b>	BT Support
<b>GNSS</b>	Supports GPS GLONASS, Galileo, BeiDou) (Optional)
Mechanical	
<b>Dimension</b>	266 x 224 x 50.4 mm
<b>Mounting</b>	VESA Mount
<b>Cooling System</b>	Fanless design
<b>Weight</b>	2.4 kg
<b>Enclosure</b>	Magnesium Alloy & ABS+PC
Environment	
<b>Operating Humidity</b>	10% to 90% RH, Non-Condensing
<b>Storage Temperature</b>	-20°C to 60°C
<b>Vibration</b>	MIL-STD-810G Method 514.6 Procedure I
<b>Drop</b>	MIL-STD-810G Method 516.6 Procedure IV
<b>Operating Temperature</b>	-10°C to 50°C (14°F to 122°F) (Battery mode) -20°C to 60°C (4°F to 158°F) (AC mode)*
<b>Shock</b>	MIL-STD-810G Method 516.6 Procedure I
<b>IP rating</b>	IP54
Certification	
<b>Certification</b>	CE, FCC
IO Ports	
<b>USB Port</b>	2 x USB3.2 Gen1x1 (Type-A)
<b>SD Card Slot</b>	1 x Micro SD card Slot
<b>Serial Port</b>	1 x RS232/422/485 (Default RS232)
<b>SIM Card Slot</b>	1 x Micro SIM card Slot

<b>Audio</b>	1 x Audio Combo Connector (Mic in / Line Out) 2 x Speaker	<b>LAN</b>	1 x Giga LAN RJ45 Connector
<b>Indicator</b>	1 x LED Indicator for power 1 x LED Indicator for HDD 1 x LED Indicator for Battery status 1 x LED Indicator for Wifi		

**Accessory**

<b>Accessory</b>	100~240V AC to 19V DC 65W Adapter Power Cord 11.1V / 5200mAh Battery Quick Start Guide Stylus	<b>Optional Accessory</b>	Adjustable Kickstand (Optional) Multi-functional Desktop Docking station (Optional) Vehicle Mounting Charger Kit (Optional) Car Power Charger (Optional) Hand Strap (Optional) Shoulder Strap (Optional) Soft Shell Case (Optional) Carry Bag (Optional)
------------------	---	---------------------------	---

**Barcode Scanner**

<b>Barcode Scanner</b>	2D Barcode Reader (Optional)
------------------------	------------------------------

**Camera**

<b>Front Camera</b>	2MP Camera (Optional)	<b>Rear Camera</b>	5MP Autofocus Camera (Optional)
---------------------	-----------------------	--------------------	---------------------------------

**DIMENSIONS** UNIT:MM

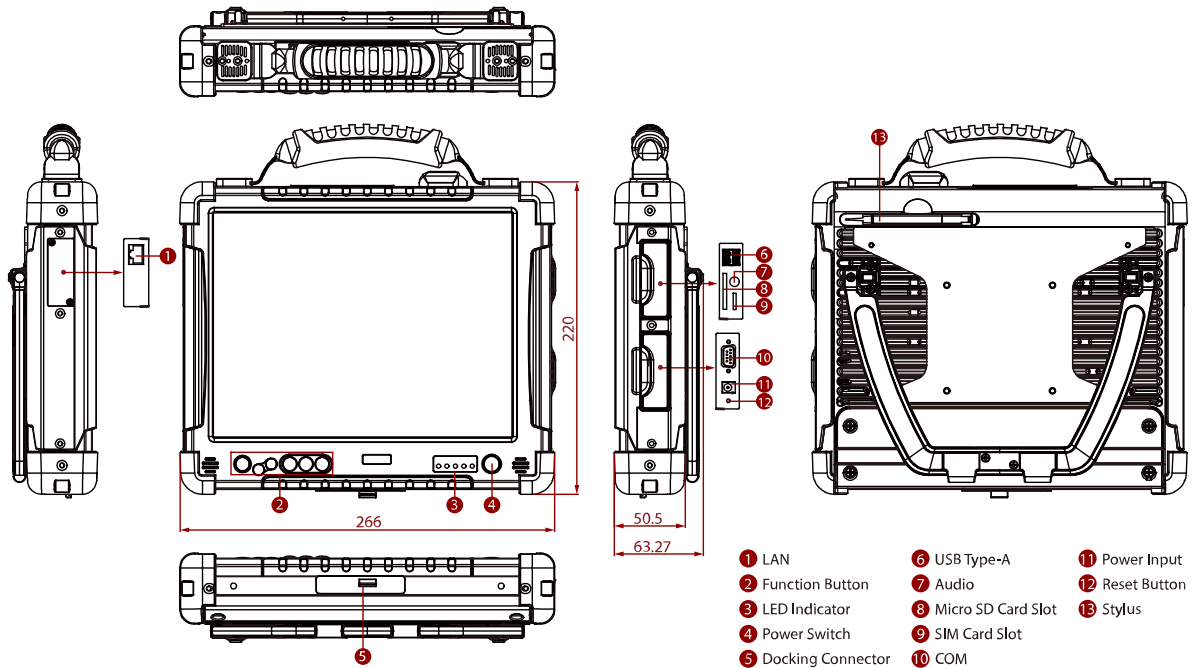

**NOTE**

1. Measured at dimming LCD brightness. Varies depending on the usage conditions, or when an external device is attached.
2. This is a simplified drawing and some components are not marked in detail.
3. The product shown in this datasheet is a standard model. For diagrams that contain customized or optional I/O, please contact the Winmate Sales Team for more information.

## Assured Systems

Assured Systems is a leading technology company with over 1,500 regular clients in 80 countries, deploying over 85,000 systems to a diverse customer base in 12 years of business. We offer high-quality and innovative rugged computing, display, networking and data collection solutions to the embedded, industrial, and digital-out-of-home market sectors.

### US

[sales@assured-systems.com](mailto:sales@assured-systems.com)

Sales: +1 347 719 4508  
Support: +1 347 719 4508

1309 Coffeen Ave  
Ste 1200  
Sheridan  
WY 82801  
USA

### EMEA

[sales@assured-systems.com](mailto:sales@assured-systems.com)

Sales: +44 (0)1785 879 050  
Support: +44 (0)1785 879 050

Unit A5 Douglas Park  
Stone Business Park  
Stone  
ST15 0YJ  
United Kingdom

VAT Number: 120 9546 28  
Business Registration Number: 07699660