

R19L100-MLA3FP

19" PCAP Rack Mount Defence Display



KEY FEATURES

- 19", 1280 x 1024 resolution
- Compliant MIL-STD 810G/ MIL-STD 461E
- Rack mount mechanical design, supports VESA mount
- PCAP multi-touch screen
- Defence-grade power connector (MIL-DTL-38999/1)
- AC 100~240V, Universal, ±10%; DC 9~36V, ±10% (Optional)
- Convenient on-screen display controls
- Defence Display



SPECIFICATIONS

Display			
Resolution	1280x1024	Size	19 inches
Contrast Ratio	1000:1	Panel Brightness	350 nits
Display Color	16.7M Colors	View Angles	85,85,80,80
Active Area	376.32x301.06 mm	Touch / Glass	Projected Capacitive Multi Touch Screen PCAP with With ITO Flim (Optional)
Environment			
Operating Humidity	10% to 95% RH	Operating Temperature	-20°C~60°C
Storage Temperature	-30°C~70°C	IP rating	Front IP65
Compliance			
MIL-STD 461E/F	RE101 / RE102 CE101 / CE102 with EMI Glass / Touch(Optional) RS101 / RS 103 CS101 / CS 106 / CS 109 / CS 114 / CS 115 / CS 116	MIL-STD 810F/G	Vibration Method 514.5 Humidity Method 507.4 Transit Drop Method516.5
Certification			
Certification	CE, FCC		
IO Ports			
USB Port	1 x USB for Touch	Video	1 x VGA 5 x BNC (R,G,B,H,V) 1 x DVI-D
Mechanical			
Dimension	482.6 x 399.3 x 79.6 mm	Mounting	Rack Mount/ VESA Mount
Enclosure	Metal Housing with Aluminum Bezel	Cooling System	Fanless Design
Accessory			
Accessory	1 x User Manual(Hardcopy) 1 x Power Cord MIL-DTL-38999/1 1 x VGA Cable 1 x DVI Cable 1 x VGA to 5 BNC Shielding Cable		

Power	
Power Rating	AC 100~240V, Universal, ±10% DC 9~36V, ±10% (Optional)
Control	
Button	7 key: Power Decrease Increase Exit/ Auto Menu Day/ Night Lock/ Unlock

DIMENSIONS UNIT:MM

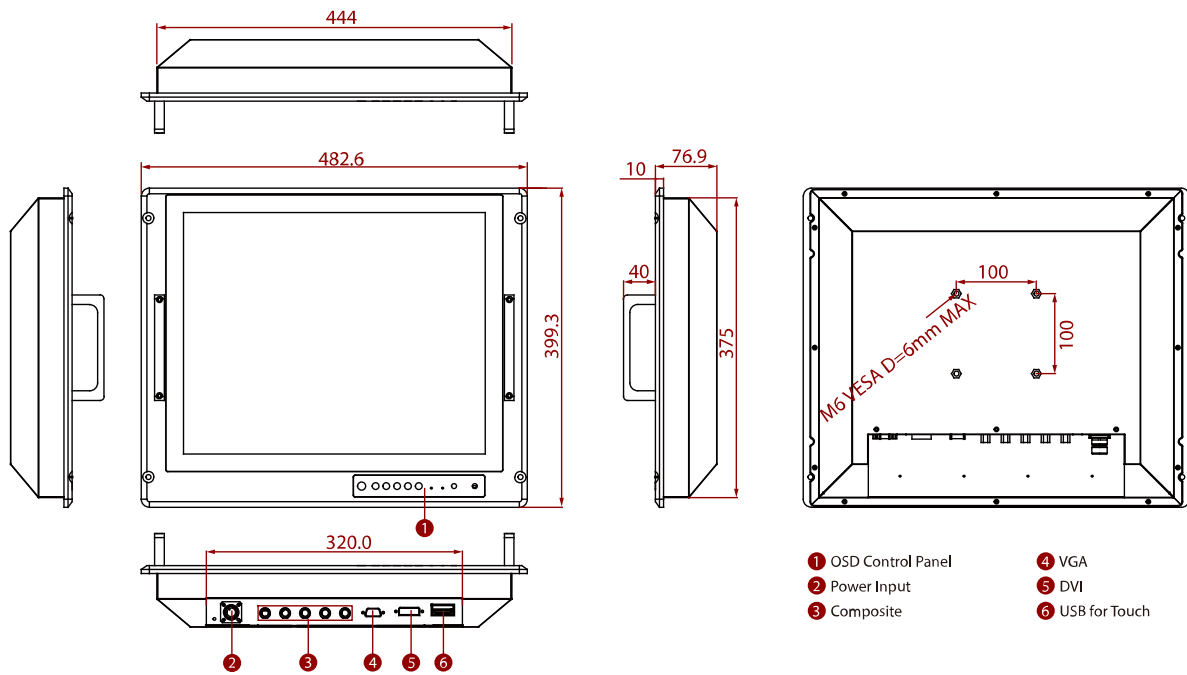

NOTE

1. The product shown in this datasheet is a standard model. For diagrams that contain customized or optional I/O, please contact the Winmate Sales Team for more information.

Assured Systems

Assured Systems is a leading technology company with over 1,500 regular clients in 80 countries, deploying over 85,000 systems to a diverse customer base in 12 years of business. We offer high-quality and innovative rugged computing, display, networking and data collection solutions to the embedded, industrial, and digital-out-of-home market sectors.

US

sales@assured-systems.com

Sales: +1 347 719 4508
Support: +1 347 719 4508

1309 Coffeen Ave
Ste 1200
Sheridan
WY 82801
USA

EMEA

sales@assured-systems.com

Sales: +44 (0)1785 879 050
Support: +44 (0)1785 879 050

Unit A5 Douglas Park
Stone Business Park
Stone
ST15 0YJ
United Kingdom

VAT Number: 120 9546 28
Business Registration Number: 07699660