



6th/7th Gen Intel® Core™ Processor  
Modular-Designed Embedded System



## EC532-KD-AI

H110



### ► Features

- Supports DDR4 SODIMM up to 32GB
- Two independent displays: 1 VGA + 1 DVI/HDMI
- Front accessible storage slots
- Rich I/O connectivity
- 3 expansion slots: PCIe x16 + PCIe x4 (PCIe x1 signal)



### ► Panel

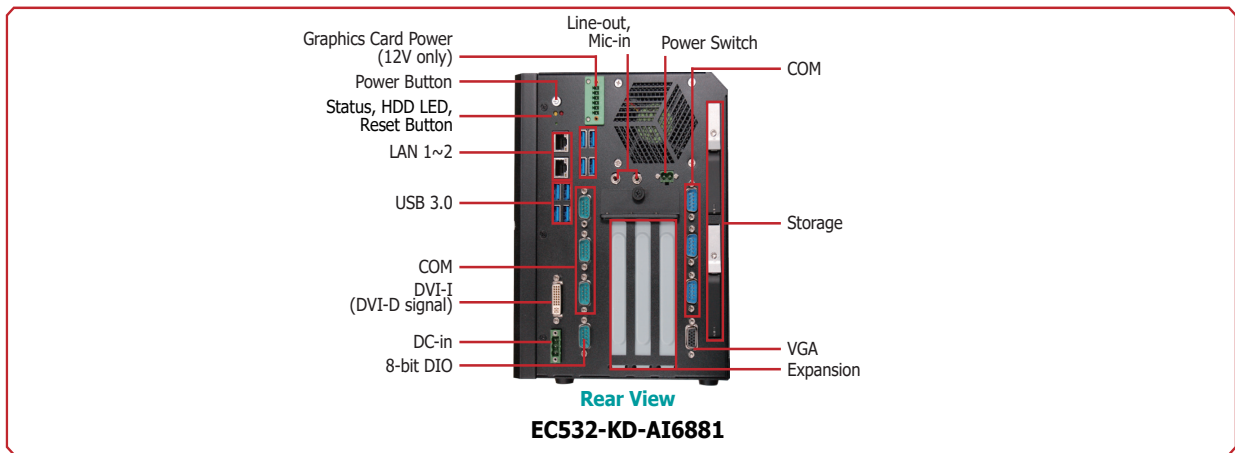

### ► Dimensions

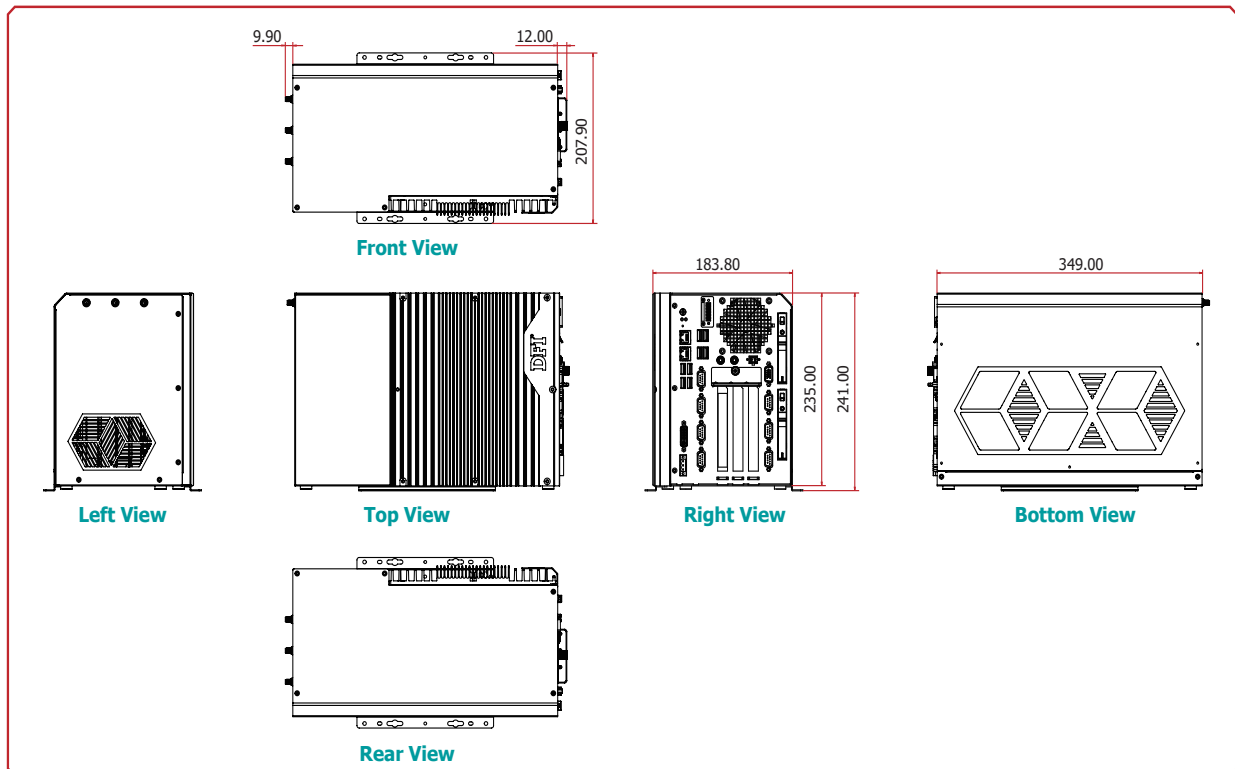



### Specifications

<b>SYSTEM</b>	<b>Processor</b>	6th/7th Generation Intel® Core™ Processors, LGA 1151 Socket Intel® Core™ i7-6700TE, Quad Core, 8M Cache, 2.4GHz (3.4GHz), 35W Intel® Core™ i5-6500TE, Quad Core, 6M Cache, 2.3GHz (3.3GHz), 35W Intel® Core™ i3-6100TE, Dual Core, 4M Cache, 2.7GHz, 35W Intel® Core™ i7-7700T, Quad Core, 8M Cache, 2.9GHz (3.8GHz), 35W Intel® Core™ i5-7500T, Quad Core, 6M Cache, 2.7GHz (3.5GHz), 35W Intel® Core™ i3-7101TE, Dual Core, 3M Cache, 3.4GHz, 35W
	<b>Chipset</b>	Intel® H110 Chipset
	<b>Memory</b>	Two 260-pin SODIMM up to 32GB <span style="float: right;">Dual Channel DDR4 1866/2133MHz</span>
	<b>BIOS</b>	Insyde SPI 128Mbit
	<b>GRAPHICS</b>	<b>Controller</b>
	<b>Feature</b>	OpenGL 5.0, DirectX 12, OpenCL 2.1 HW Decode: AVC/H.264, MPEG2, VC1/WMV9, JPEG/MJPEG, HEVC/H265, VP8, VP9 HW Encode: MPEG2, AVC/H264, JPEG, HEVC/H265, VP8, VP9
	<b>Display</b>	1 x VGA 1 x DVI-I (DVI-D signal)/HDMI (HDMI available upon request) <span style="float: right;">VGA: resolution up to 1920x1200 @ 60Hz DVI: resolution up to 1920x1200 @ 60Hz</span>
	<b>Dual Displays</b>	VGA + DVI (DVI-D signal) (Default) VGA + HDMI (available upon request)
<b>STORAGE</b>	<b>External</b>	2 x 2.5" SATA 3.0 Drive Bay (Removable, support thickness 7mm HDD or SSD) (RAID 0/1)
<b>EXPANSION</b>	<b>Interface</b>	1 x PCIe x16 (PCIe x16 signal) + 1 x PCIe x4 (PCIe x1 signal) 1 x Full-size Mini PCIe (PCIe/USB2.0) 1 x Half-size Mini PCIe (USB2.0/mSATA)
<b>ETHERNET</b>	<b>Controller</b>	1 x Intel® I211AT PCIe (10/100/1000Mbps) 1 x Intel® I219LM with iAMT11.0 PCIe (10/100/1000Mbps) (only Core i7/i5 supports iAMT)
<b>LED</b>	<b>Indicators</b>	1 x Status LED 1 x HDD LED
<b>REAR I/O</b>	<b>Ethernet</b>	2 x GbE (RJ-45)
	<b>Serial</b>	4 x RS-232/422/485 (DB-9) (RS-232 with power) 2 x RS-232/422/485 (DB-9)
	<b>USB</b>	8 x USB 3.0 (type A)
	<b>Display</b>	1 x VGA 1 x DVI-I (DVI-D signal)/(HDMI available upon request)
	<b>Audio</b>	1 x Line-out 1 x Mic-in
	<b>DIO</b>	1 x 8-bit DIO
	<b>Buttons</b>	1 x Power Button 1 x Reset Button
	<b>Antenna Hole</b>	3 x Antenna Hole
<b>WATCHDOG TIMER</b>	<b>Output &amp; Interval</b>	System Reset, Programmable via Software from 1 to 255 Seconds
<b>SECURITY</b>	<b>TPM</b>	TPM 1.2 (optional)
<b>POWER</b>	<b>Type</b>	Wide Range 9~36V
	<b>Connector</b>	3-pole Terminal Block
<b>OS SUPPORT</b>		Windows 7 (32/64-bit) <span style="float: right;">Windows 8.1 (64-bit)</span> Windows 10
<b>MECHANISM</b>	<b>Construction</b>	Aluminum + Sheet Metal
	<b>Mounting</b>	Wall Mount
	<b>Dimensions (W x H x D)</b>	235mm x 102.5mm x 222mm (W x H x D)
	<b>Weight</b>	TBD
<b>ENVIRONMENT</b>	<b>Operating Temperature</b>	0 to 45°C (HDD, with 0.7m/s air flow) -20 to 50°C (SSD or mSATA-mini, with 0.7m/s air flow)
	<b>Storage Temperature</b>	-20 to 85°C
	<b>Relative Humidity</b>	5 to 90% RH (non-condensing)
<b>STANDARDS AND CERTIFICATIONS</b>	<b>Shock</b>	Half sine wave 3G, 11ms, 3 shock per axis
	<b>Vibration</b>	IEC68-2-64
	<b>Certification</b>	CE, FCC Class A, RoHS

## Assured Systems

Assured Systems is a leading technology company with over 1,500 regular clients in 80 countries, deploying over 85,000 systems to a diverse customer base in 12 years of business. We offer high-quality and innovative rugged computing, display, networking and data collection solutions to the embedded, industrial, and digital-out-of-home market sectors.

### US

[sales@assured-systems.com](mailto:sales@assured-systems.com)

Sales: +1 347 719 4508  
Support: +1 347 719 4508

1309 Coffeen Ave  
Ste 1200  
Sheridan  
WY 82801  
USA

### EMEA

[sales@assured-systems.com](mailto:sales@assured-systems.com)

Sales: +44 (0)1785 879 050  
Support: +44 (0)1785 879 050

Unit A5 Douglas Park  
Stone Business Park  
Stone  
ST15 0YJ  
United Kingdom

VAT Number: 120 9546 28  
Business Registration Number: 07699660