

Military Grade Rack Mount LCD

Rack Mount LCD



24" (9U)

Specifications

RoHS
COMPLIANT
2011/65/EU

Model Name	W24L100-RKS1ML
Viewable Size Image	24"
Active Display Area(mm)	518.4(H)x324(V)
Pixel Pitch(mm)	0.270(H)x0.270(V)
Number of Pixels	1920x1200
Contrast Ratio	1000:1(typ.)
Display Color	16.7M (colors)
Brightness(cd/m ²)	300(typ)
Viewing Angle(CR>=10)	-89~89(H);-89~89(V)
Synchronization Range Horizontal/Vertical	31.5~80.0KHz/60~75Hz
Recommended Resolution	1920x1200@60Hz, 75Hz
Signal Connector	1 x D-Sub15 (VGA) 1 x DVI-D 5 x BNCs
Power Source	AC100~240V, Universal, ±10% DC 9-36V, ±10%(Optional)
Power Consumption	66W typical, normal operation
Power Management	VESA DPMS Compliant
Plug & Play	VESA DDC 1/2B
Operating Temperature	0°C ~ 50°C Wide temperature solution by request
Storage Temperature	-10°C ~ 60°C

- Anti-Corrosion Housing / Fanless
- Compliant with MIL-STD-810G/F
- Flush Rack / Rack Mount Mechanical Design
- Convenient On-Screen Display Controls
- AC built-in Power input / Isolation DC 9~36V Power input (Optional)
- Built-in Light Sensor for auto brightness control
- Military Grade Power Connector (MIL-DTL-38999/1)
- Standard AR Glass

Environmental(MIL-STD 810F/G Compliance)

Vibration	MIL-STD-810F/G Method 514.5
Humidity	MIL-STD-810F/G Method 507.4
Transit Drop	MIL-STD-810F/G Method 516.5

Environmental(MIL-461E/F Compliance)

RE	RE101 / RE102
CE	CE 101 / CE102

Mechanical Drawing

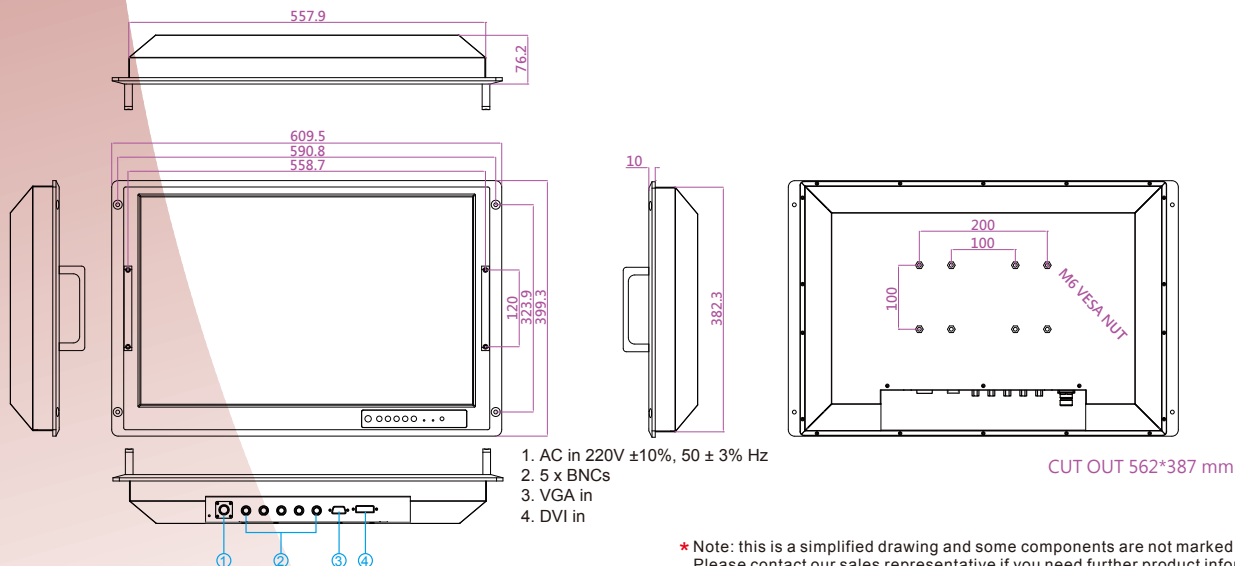

* Note: this is a simplified drawing and some components are not marked in detail. Please contact our sales representative if you need further product information.

Note: All Specifications are subject to change without prior notice!

Revised Date: 25-Feb-2019 V2.0

Assured Systems

Assured Systems is a leading technology company with over 1,500 regular clients in 80 countries, deploying over 85,000 systems to a diverse customer base in 12 years of business. We offer high-quality and innovative rugged computing, display, networking and data collection solutions to the embedded, industrial, and digital-out-of-home market sectors.

US

sales@assured-systems.com

Sales: +1 347 719 4508
Support: +1 347 719 4508

1309 Coffeen Ave
Ste 1200
Sheridan
WY 82801
USA

EMEA

sales@assured-systems.com

Sales: +44 (0)1785 879 050
Support: +44 (0)1785 879 050

Unit A5 Douglas Park
Stone Business Park
Stone
ST15 0YJ
United Kingdom

VAT Number: 120 9546 28
Business Registration Number: 07699660