

19" Military Grade Display

Military Grade Display

MODEL : R19L100-MLA3

Mechanical Design



Features

- Front sealed IP67 aluminum compact housing design
- 19-inch 1280x1024 panel with ITO EMI shielding protection glass
- Fanless, streamlined enclosure for highly efficient heat dissipation
- MIL-STD-810F/G Compliant
- MIL-STD-461E/F Compliant
- Front control membrane keys
- -40°C~70°C wide operating temperature
- Built-in intelligent heater design

I/O View

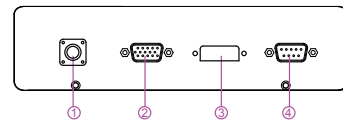

1. Military Grade 9~36V isolation DC in
2. VGA input
3. DVI-D input
4. RS232 Remote control (Optional)

*Note: this is a simplified drawing and some components are not marked in detail. Please contact our sales representative if you need further product information.

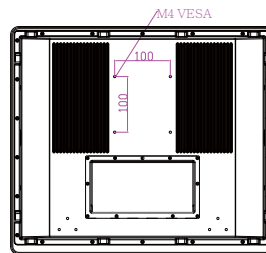
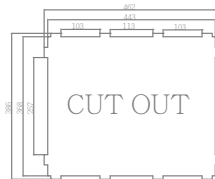
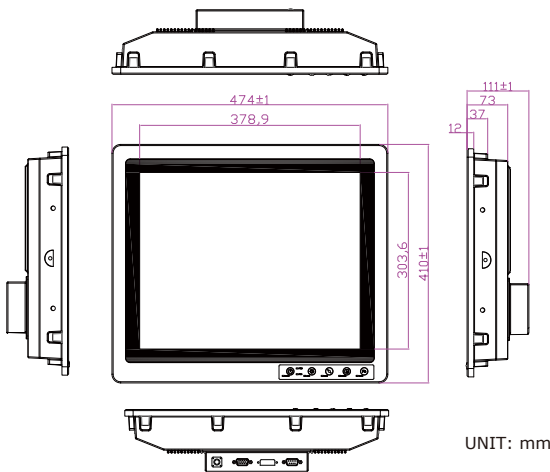

UNIT: mm

System Specifications :

- Model Name : R19L100-MLA3
- Resolutions : 1280 x 1024
- Brightness : 350 nits
- Contrast Ratio : 1000 : 1 (typ.)
- Viewing Angles : -85~85(H); -80~80(V)
- Max Colors : 16.7M
- Picture in Picture : Support PIP Function (VGA in DVI / DVI in VGA)
- Recommended Resolution : 1280 x 1024 @ 60Hz~75Hz
- Signal Input : 15 pin D-Sub / DVI-D
- Power Input : 9~36V isolation DC in, with External AC to DC Adapter (100-240V AC)
- Protection Glass : Yes

Environment Considerations :

- Operating Temperature : -40°C~70°C
- Storage Temperature : -40°C~70°C
- Operating Humidity : 5 to 95%

Mechanical Specification :

- Mechanical Housing : Rack Mount
- Dimension(W x H xD) : 474mm x 410mm x 111mm
- Gross Weight : 10.2 kg
- Net Weight : 9.0 kg

Connectors :

- 1 x D-Sub 15 VGA
- 1 x DVI-D
- 1 x 9~36V DC Power input with isolation
- 1 x RS232 Remote control (Optional)

Accessories :

- 1 x Driver & Manual CD
- 1 x AC to DC 12V 50W Power Adapter with military grade connector
- VGA / DVI / RS232 (Optional) external cable

Ordering Information :

- R19L100-MLA3/GS Anti-Reflective Glass (Default)
- R19L100-MLA3/ITO ITO EMI shielding Glass *
- R19L100-MLA3/ATR ELO 5 wired Resistive Touch Sensor (RS232 Interface)
- R19L100-MLA3/ATR-ITO ELO 5 wired Resistive Touch with EMI Mesh Filter

Environmental(MIL-STD 810F/G Compliance)

- Vibration : MIL-STD-810F/G Method 514.5
- Humidity : MIL-STD-810F/G Method 507.4
- Transit Drop : MIL-STD-810F/G Method 516.5

Environmental(MIL-STD 461E/F Compliance)

- RE : RE 101 / RE 102
- CE : CE 101 / CE 102
- Optional with EMI Glass / Touch
- CS : RS101 / RS103
- CS : CS 101 / CS 106 / CS 109 / CS 114 / CS 115 / CS 116

* If you require external test report, Winmate will charge NRE fee.

Assured Systems

Assured Systems is a leading technology company with over 1,500 regular clients in 80 countries, deploying over 85,000 systems to a diverse customer base in 12 years of business. We offer high-quality and innovative rugged computing, display, networking and data collection solutions to the embedded, industrial, and digital-out-of-home market sectors.

US

sales@assured-systems.com

Sales: +1 347 719 4508
Support: +1 347 719 4508

1309 Coffeen Ave
Ste 1200
Sheridan
WY 82801
USA

EMEA

sales@assured-systems.com

Sales: +44 (0)1785 879 050
Support: +44 (0)1785 879 050

Unit A5 Douglas Park
Stone Business Park
Stone
ST15 0YJ
United Kingdom

VAT Number: 120 9546 28
Business Registration Number: 07699660