

R19IAD7T-GPM1

19" Edge AI Panel PC with Intel® Alder Lake S / Raptor Lake S Processor



KEY FEATURES

- 19", 1280 x 1024 resolution with P-CAP touchscreen
- Supports Intel® 12/14th generation Alder Lake S / Raptor Lake S processor
- Supports single NVIDIA RTX™ A2000/ T1000 GPU
- Supports Intel® vPro
- Up to 2 x 262pin SODIMM DDR5 4800MHz up to 64GB(32GB per Slot)
- 2 x Intel 2.5 Gigabit LAN, 4 x USB3.2 Gen 2x1
- Supports Two display, 1 x HDMI 2.0, 1 x DP 1.4a
- 80 ~ 264 VAC Power Input with 3 Pin AC Plug



SPECIFICATIONS

Display

Resolution	1280x1024	Size	19.0 inches
Contrast Ratio	1000:1	Panel Brightness	250.0 nits
View Angles	85,85,80,80	Active Area	376.32x301.06 mm
Touch / Glass	Projected Capacitive Multi Touch Screen		

System Specification

Processor	Intel® Core™ i7-12700TE(up to 4.6GHz) Intel® Core™ i9-12900TE(up to 4.80GHz) (Optional) Intel® Core™ i7-14700T(up to 5.2GHz) (Optional) Intel® Core™ i9-14900T(up to 5.5GHz) (Optional)	Chipset	Intel® R680E
Memory	SO-DIMM, DDR5 4800 MHz, 8+8GB 16+16GB (Optional) 32+32GB (Optional)	Storage	1 x M.2 2280 M-Key NVMe SSD, 512GB 1TB (Optional) 2TB (Optional)
Ethernet controller	2 x Intel® 2.5 Gigabit Ethernet Controller	Security	TPM 2.0
Operating System	Windows 11 IoT Enterprise (64 bit) (Optional) Windows 11 Pro 64 bit (Optional) Linux Ubuntu 22.04(Do not support Wake on Touch) (Optional)	WLAN	Support (Optional)
BT	Support (Optional)	AI Accelerator	Hailo 8™ AI accelerator module, up to 26 TOPS(When using this feature, WLAN will not be supported) (Optional)
Graphic Card	NVIDIA® RTX A2000 12GB Graphic Card (Optional) NVIDIA® T1000 8GB Graphic Card (Optional)		

Mechanical

Dimension	445 x 370 x 71.5 mm	Weight	6.5 kg
Mounting	Panel mount VESA Mount	Enclosure	Metal Housing
Cooling System	Fan design	Cut out	425 x 340 mm

Environment

Operating Humidity	10% to 90% RH, Non-Condensing	Operating Temperature	0°C to 55°C
Storage Temperature	-10°C to 60°C	IP rating	Front IP65

Certification	
Certification	CE, FCC
IO Ports	
Power Input	1 x 3 Pin AC Plug
Video	1 x DP1.4a DP++ , Max resolution up to 4096x2160@60Hz 1 x HDMI 2.0b , Max resolution up to 4096x2160@60Hz (Optional)
Expansion Port	1 x M.2 2280 M-Key Slot (for NVME SSD) 1 x M.2 2230 E-Key Slot (for Wi-Fi module or Hailo 8™ AI accelerator module) 1 x PCIe 5.0 (x16) slot
Indicator	1 x LED Indicator for power 1 x LED Indicator for storage
Control	
Button	1 x AC Power Switch 1 x Power Button 1 x Clear CMOS Button 2 x Reset Button
Accessory	
Accessory	Power Cord VESA screws Mounting screws
Power	
Power Rating	80 ~ 264VAC
Consumption	300W

DIMENSIONS UNIT:MM

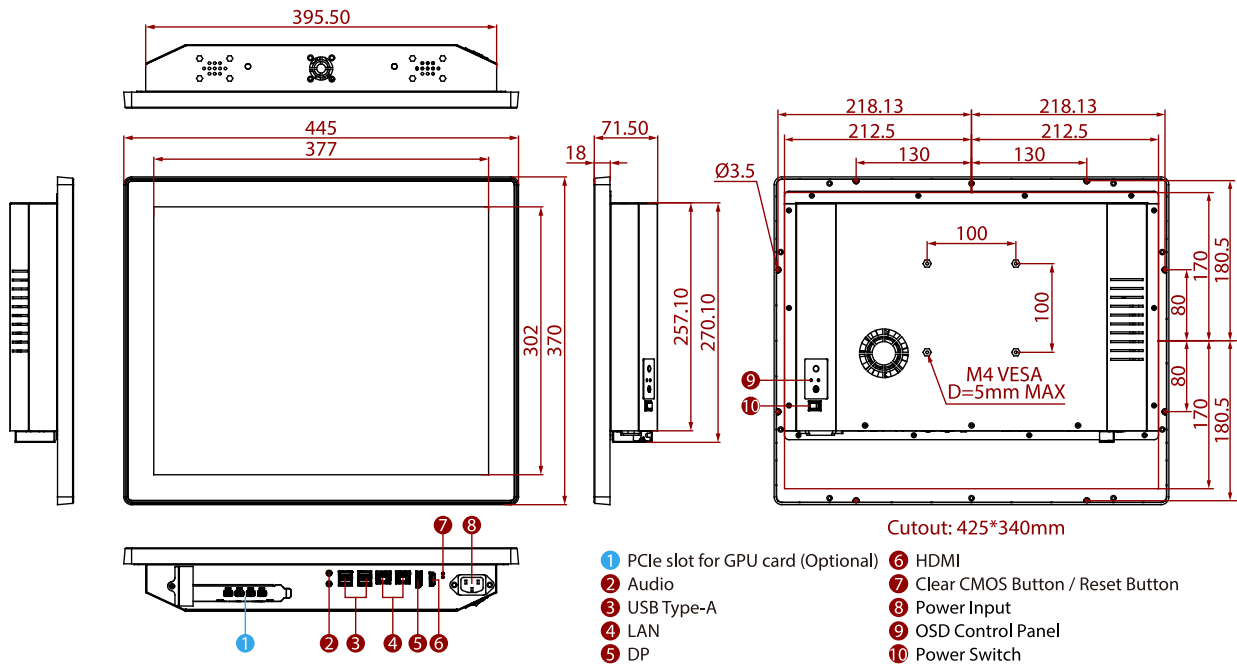

NOTE

- 1.This is a simplified drawing and some components are not marked in detail.
- 2.Please contact our sales representative if you need further product information.
- 3.All specifications are subject to change without prior notice.
- 4.The product shown in this datasheet is a standard model.For diagrams that contain customized or optional I / O, please contact the Winmate Sales Team for more information.

Assured Systems

Assured Systems is a leading technology company with over 1,500 regular clients in 80 countries, deploying over 85,000 systems to a diverse customer base in 12 years of business. We offer high-quality and innovative rugged computing, display, networking and data collection solutions to the embedded, industrial, and digital-out-of-home market sectors.

US

sales@assured-systems.com

Sales: +1 347 719 4508
Support: +1 347 719 4508

1309 Coffeen Ave
Ste 1200
Sheridan
WY 82801
USA

EMEA

sales@assured-systems.com

Sales: +44 (0)1785 879 050
Support: +44 (0)1785 879 050

Unit A5 Douglas Park
Stone Business Park
Stone
ST15 0YJ
United Kingdom

VAT Number: 120 9546 28
Business Registration Number: 07699660