



Surgical Monitor
RadiForce[®] LX300W



The 29.8-inch 4 megapixel monitor in widescreen format is designed for use in operating rooms (interventional radiology, cardiology, or surgery). It is a value for money solution for smaller examination and operating rooms where individual monitors increasingly are being replaced by large-format screens capable of displaying multiple image sources simultaneously.

- Environmentally-friendly LED backlight offers a maximum brightness of 750 cd/m².
- Intelligent cooling system automatically measures the internal temperature of the monitor and operates with a regulated fan or without any ventilation at all.
- Fail-safe function displays additional video signal in the upper left corner of the monitor in case of interruptions in the system's image transmission.
- Up to three video sources can be displayed simultaneously.
- Flexible operating modes in landscape and portrait format.
- Grayscale tones adjusted at the factory to meet DICOM Part 14 standard for optimum viewing of medical DICOM images.
- Five factory calibrated Look-up tables adaptable to diverse modality environments.

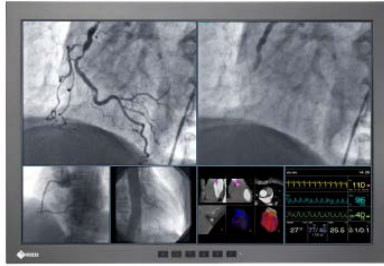

RadiForce® LX300W

Everything in a Single Glance

Large widescreen monitors with high resolution can be used instead of single 1 Megapixel monitors in ceiling suspensions. Compared with multi-monitor scenarios, these large screen monitors have no regional color differences or obtrusive bezels, thus reducing eye fatigue and the potential for distraction.

Controlled Cooling

The monitor features intelligent cooling concept by measuring and controlling the inside temperature. A mode without fan cooling is selectable so the controlled laminar airflow will be undisturbed within the room as far as possible.

Fail-Safe Function

Special fail-safe mode through DVI input for emergency information from the system for a certain timing. As soon as the timing is active, the information will be shown immediately on the upper left screen side.

Flexible Operation Modes

Up to three input signals can be displayed simultaneously. The images can be arranged side by side or as Picture in Picture (PiP), while image rotation is managed by the monitor.

Environmentally-Friendly LED Backlight

By utilizing an energy-efficient LED as a backlight, the monitor achieves a high-brightness and low power consumption at the same time. Unlike conventional CCFL backlights, LED backlights deteriorate more slowly and thus the monitor offers a longer service life. Since the LED backlight is mercury free, it will reduce any potential impact on the environment when it is disposed of.

Communication Interface

The communication interface is routed via the DVI or USB connection. The operating states of the monitor can be read and switched via the interface, e.g. in Power Safe Mode. In particular, the monitor functionality can be queried using the interface.

LCD Panel Protector for Easy Cleaning

A monitor model with panel protector, pre-attached in the factory, is available to protect against dust and scratches. Clean lines and smooth surfaces also allow easy cleaning and disinfecting.

Diagnostic Precision with Factory Adjustment

To ensure the most accurate and consistent shadings possible, EIZO carefully measures and sets every grayscale tone on the production line to offer monitors fully compliant with DICOM Part 14.

Brightness Uniformity for a Steadier Image Across the Screen

The Digital Uniformity Equalizer (DUE) function provides optimum backlight luminance uniformity which is considered difficult to attain due to the characteristics of LCD monitors, especially with larger screen sizes.

Customer Assurance with Medical Standards

EIZO monitors meet the strictest medical, safety, and EMC emission standards.

Specifications

Model Variations	LX300W: Without Stand, without Panel Protector LX300W-S: With Stand, without Panel Protector LX300W-P: Without Stand, with Panel Protector
Cabinet Color	Black
Panel Type	TFT Color LCD Panel (IPS)
Backlight	White LED
Panel Size	75.6 cm / 29.8" (756 mm diagonal)
Native Resolution	2560 x 1600 (16:10 aspect ratio)
Viewable Image Size (H x V)	641 x 405 mm
Pixel Pitch	0.2505 x 0.2505 mm
Display Colors	10-bit colors (DisplayPort): 1.07 billion (maximum) colors 8-bit colors: 16.77 million colors
Viewing Angles (H,V)	170°, 170°
Brightness (typical)	750 cd/m ²
Recommended Brightness for Calibration	400 cd/m ²
Contrast Ratio (typical)	1100:1
Response Time (typical)	20 ms (On/Off)
Input Terminals	DVI Single Link / Dual Link x 1, DVI Single Link x 1, HDMI connector (DVI Single Link signal only) x 1, DisplayPort 1.1 x 1
Scanning Frequency (H, V)	31 - 100 kHz, 29.5 - 61 Hz Frame synchronous mode: 59.5 - 60.5 Hz
USB Ports / Standard	1 upstream, 2 downstream / Rev. 2.0
Power Requirements	AC 100 - 120 V, 200 - 240 V: 50 - 60 Hz
Maximum Power Consumption	150 W
Power Save Mode	Less than 20 W
Standby Mode (typical)	1 W
Power Management	DVI DMPM, DisplayPort 1.1a
Sensor	Backlight Sensor
OSD Languages	English, German
Net Weight	LX300W: 15.5 kg +/- 1 kg LX300W-S: 19.5 kg +/- 1 kg LX300W-P: 18.5 kg +/- 1 kg
Environmental Requirements	IP20
Hole Spacing (VESA Standard)	200 x 100 mm and 100 x 100 mm
Certifications and Standards	CE (Medical Device Directive), EN60601-1, UL60601-1, CAN/CSA-C22.2 No. 60601-1-08, IEC60601-1, FCC-B, C-tick, RoHS, China RoHS, WEEE
Supplied Accessories	AC power cord (eu, us, jp, LX300W-S only), dual link signal cable (DVI-D ~ DVI-D, LX300W-S only), Utility Disk (Instruction for Use)
Warranty	Five Years

Dimensions (Unit:mm)

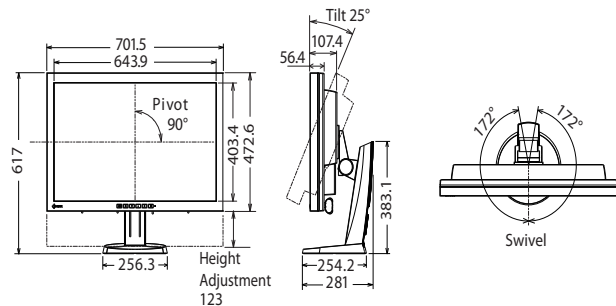

EIZO GmbH

Siemensallee 84, 76187 Karlsruhe, Germany
Phone +49 721 20321 0, Fax +49 721 20321 474
www.eizo.com

All product names are trademarks or registered trademarks of their respective companies.
EIZO, RadiForce, FlexScan, ScreenManager, RadiCS and RadiNET are registered trademarks of Eizo Corporation. Specifications are subject to change without notice.

Copyright © 2014 EIZO GmbH. All rights reserved. (1402)

Assured Systems

Assured Systems is a leading technology company with over 1,500 regular clients in 80 countries, deploying over 85,000 systems to a diverse customer base in 12 years of business. We offer high-quality and innovative rugged computing, display, networking and data collection solutions to the embedded, industrial, and digital-out-of-home market sectors.

US

sales@assured-systems.com

Sales: +1 347 719 4508
Support: +1 347 719 4508

1309 Coffeen Ave
Ste 1200
Sheridan
WY 82801
USA

EMEA

sales@assured-systems.com

Sales: +44 (0)1785 879 050
Support: +44 (0)1785 879 050

Unit A5 Douglas Park
Stone Business Park
Stone
ST15 0YJ
United Kingdom

VAT Number: 120 9546 28
Business Registration Number: 07699660