

E430RQ8

4.3" Qualcomm® Snapdragon™ 660 Rugged Handheld Computer

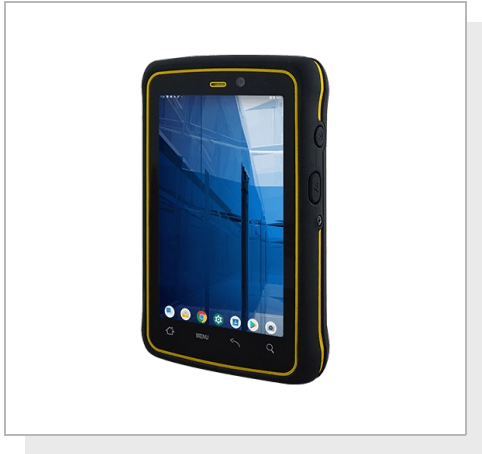

KEY FEATURES

- 4.3" 800 x 480 Panel with direct optical bonding
- IP65 waterproof and dustproof
- Optional 1D/2D Barcode Reader for data collection
- Qualcomm® Snapdragon™ 660 (Octa-core 2.2 GHz)
- Supports Android 9.0



SPECIFICATIONS

Display			
Resolution	800x480	Size	4.3 inches
Contrast Ratio	800:1	Panel Brightness	400 nits
View Angles	80,80,80,80	Type	Projected Capacitive Multi Touch
System Specification			
Processor	Qualcomm® Snapdragon™ 660 (Octa-Core 2.2 GHz)	Memory	3GB
Storage	32GB	Operating System	Android 9.0
WLAN	802.11 a/b/g/n/ac mode	BT	BT Support
RFID	Default NFC (Read / Write, Peer to Peer mode)	Sensors	Ambient Light Sensor, E-Compass, Gyro, Acceleration Sensors, Automatic Screen Rotation
Camera			
Front Camera	8MP Camera	Rear Camera	13MP Camera with LED Auxiliary Light (Auto Focus)
Mechanical			
Dimension	132.57 x 81.87 x 27.4 mm	Weight	260g
IO Ports			
USB Port	1 x USB 3.0 Type C (OTG)	SD Card Slot	1 x Micro SD Card Slot
Audio	1 x Built-in Mic 1 x Speaker	Indicator	1 x LED Indicators (Power, Battery)
Docking Connector	1 x Docking Connector		
Environment			
Operating Humidity	5% to 95% RH, Non-Condensing	Operating Temperature	-10°C to 50°C (Battery mode)
Storage Temperature	-30°C to 70°C	Shock	MIL-STD-810G Method 516.6 Procedure I
Vibration	MIL-STD-810G Method 514.6 Procedure I	IP rating	IP65 Certified, Waterproof and Dustproof
Drop	MIL-STD-810G Method 516.6, 5 ft		
Certification			
Certification	CE, FCC		
Control			
Button	1 x Volume +/- , 1 x Power Button, 1 x Function		

Button, 4 Capacitive Button (1 x Home, 1 x Menu, 1 x Esc, 1 x Search)

Power

Battery	3.7V 3900mAh	Battery Operating Time	20Hr
Power Rating	5V 1A	Adapter	5V 1A Adapter

Security Function

SOTI MobiControl	SOTI MobiControl Compliance
-------------------------	-----------------------------

Accessory

Accessory	Universal Adapter USB Type-C Cable Battery Hand Strap	Optional Accessory	Charging Dock 2 bay Charging Dock 6 bay Battery Charging Dock 2 bay Battery Charging Dock 6 bay Vehicle Charging Dock Battery Leather Holster Lanyard Micro SD Card
------------------	--	---------------------------	---

Barcode Scanner

Barcode Scanner	1D/2D Barcode Reader (Optional)
------------------------	---------------------------------

DIMENSIONS UNIT:MM

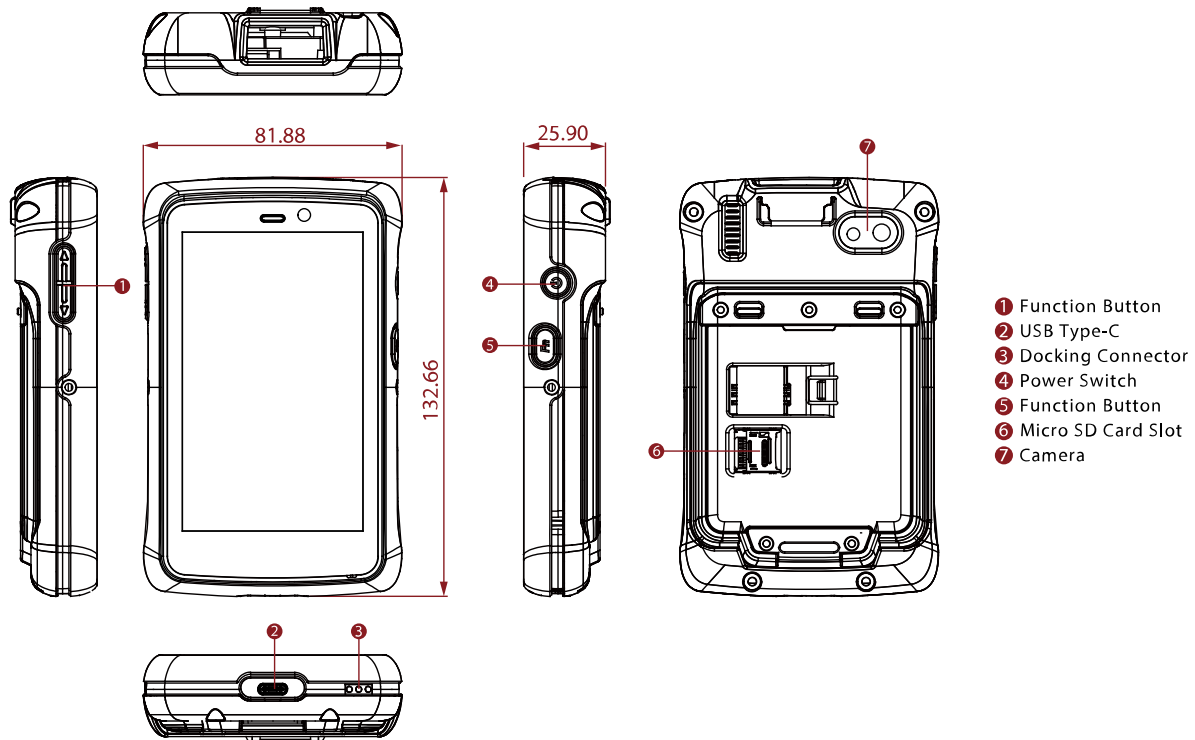

NOTE

1. Total usable memory will be less dependent upon actual system configuration.
2. SOTI is available upon request.
3. Length measurements do not include protrusions.
4. The drop test with a high-capacity battery must come with a hand strap.
5. Measured at dimming LCD brightness. Varies depending on the usage conditions, or when an external device is attached.
6. Accessories and Integrated Options may vary depending on your configuration.
7. This is a simplified drawing and some components are not marked in detail.
8. The product shown in this datasheet is a standard model. For diagrams that contain customized or optional I/O, please contact the Winmate Sales Team for more information.

Assured Systems

Assured Systems is a leading technology company with over 1,500 regular clients in 80 countries, deploying over 85,000 systems to a diverse customer base in 12 years of business. We offer high-quality and innovative rugged computing, display, networking and data collection solutions to the embedded, industrial, and digital-out-of-home market sectors.

US

sales@assured-systems.com

Sales: +1 347 719 4508
Support: +1 347 719 4508

1309 Coffeen Ave
Ste 1200
Sheridan
WY 82801
USA

EMEA

sales@assured-systems.com

Sales: +44 (0)1785 879 050
Support: +44 (0)1785 879 050

Unit A5 Douglas Park
Stone Business Park
Stone
ST15 0YJ
United Kingdom

VAT Number: 120 9546 28
Business Registration Number: 07699660