

FABS-110P/R/G(H)

10.1" Flat Front Panel IP66 Stainless Chassis Display

Industrial Panel PC

HMI Controller

Industrial Display Monitor

Box PC



Features

- Stainless steel front bezel display
- Flat front panel touch screen
- IP66/IP69K compliant front bezel
- VGA/DP/DVI/HDMI input
- OSD on the rear side
- System power LED light
- High brightness LCD for option
- Wide range DC 9~36V power input



Specifications

| I/O Port | |
|-------------|--|
| VGA | 1 x VGA |
| DVI | 1 x DVI-D (share with HDMI) |
| DP | 1 x DP |
| HDMI | 1 x HDMI (share with DVI-D) |
| Audio | 1 x Audio line-in phone jack |
| OSD Control | OSD at rear side |
| Membrane | On board controller, extendable key pad from connector |
| Power | 1 x 3-pin terminal block for DC 9~36V power input |
| Others | 1 x USB type B for touch control Optional I/O: 1 x Speaker |

| Display | Standard | High Brightness Optional |
|--------------------------------|-----------------|--------------------------|
| Display Type | 10.1" TFT-LCD | 10.1" TFT-LCD |
| Max. Resolution | 1280 x 800 | 1280 x 800 |
| Max. Color | 16.7M | 16.7M |
| Luminance (cd/m ²) | 350/300 | 1000 |
| View Angle | 170(H) / 170(V) | 170(H) / 170(V) |
| Contrast | 800:1 | 1000:1 |
| Backlight Lifetime | 25,000 hrs | 50,000 hrs |

| Touch Screen | |
|-----------------------|--|
| Type | Projected Capacitive Touch (for P model) Resistive Touch (for R model) Glass (for G model) |
| Interface | USB |
| Light Transmission(%) | Resistive Touch: over 80% Projected Capacitive Touch: over 90% |

| Power | |
|-------------------|---------------|
| Power Input | DC 9~36V |
| Power Consumption | FABS-110P: 6W |

| Mechanical | |
|--------------------|---|
| Construction | 304 Stainless steel front bezel (Default) 316L Stainless steel front bezel (Optional) Aluminum die-casting back cover |
| Mounting | Panel mount, VESA mount 100 x 100 |
| IP Rating | IP66/IP69K compliant front bezel |
| Dimensions (WxHxD) | 296 x 200 x 46.9 mm |
| Net Weight | 2.3 kg |

Dimensions

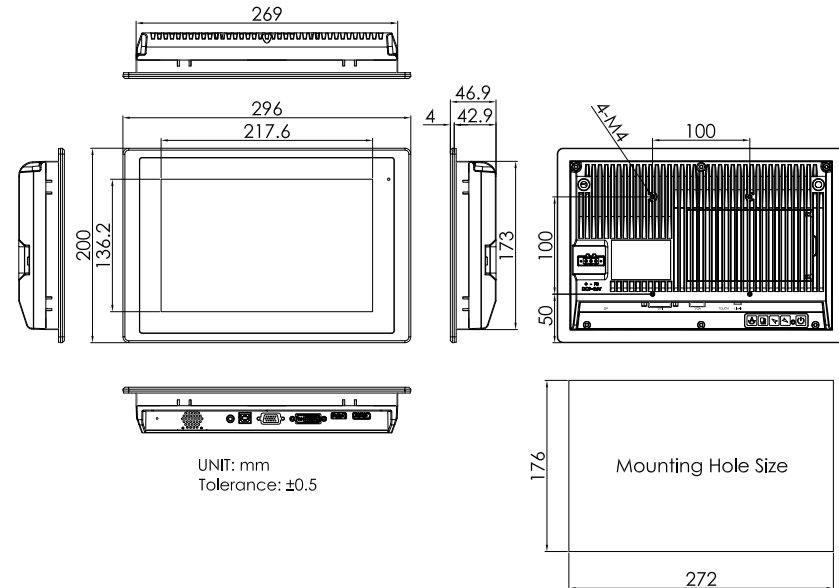

| Environmental | |
|-----------------------|---|
| Operating Temperature | 0~50°C / -20~60°C (option) |
| Storage Temperature | -30~70°C |
| Humidity | 10 to 95% @ 40°C, Non-condensing |
| Certificate | R/P/G/RH/PH/GH Model: CE/FCC Class A P/G Model is compliance with EN 1672-2 (option) |
| Vibration | 1G/5~500Hz (Random) / Operation |
| Shock | 15G peak acceleration (11 msec. duration) / Operation |

Assured Systems

Assured Systems is a leading technology company with over 1,500 regular clients in 80 countries, deploying over 85,000 systems to a diverse customer base in 12 years of business. We offer high-quality and innovative rugged computing, display, networking and data collection solutions to the embedded, industrial, and digital-out-of-home market sectors.

US

sales@assured-systems.com

Sales: +1 347 719 4508
Support: +1 347 719 4508

1309 Coffeen Ave
Ste 1200
Sheridan
WY 82801
USA

EMEA

sales@assured-systems.com

Sales: +44 (0)1785 879 050
Support: +44 (0)1785 879 050

Unit A5 Douglas Park
Stone Business Park
Stone
ST15 0YJ
United Kingdom

VAT Number: 120 9546 28
Business Registration Number: 07699660