

W10L100-GCH2

10.1" G-WIN GC Series Front IP65 PCAP Display



KEY FEATURES

- 10.1" 1280 x 800 Resolution Front IP65 PCAP Display
- Projected Capacitive Multi-Touch (P-Cap)
- Front IP65 Water and Dust Proof
- VGA input and variety of optional connectors
- USB port for touch
- Stylish and elegant design



SPECIFICATIONS

| Display | | | |
|----------------------------|--|------------------------------|--|
| Resolution | 1280x800 | Size | 10.1 inches |
| Contrast Ratio | 800:1 | Panel Brightness | 350.0 nits |
| Display Color | 16.7M Colors | View Angles | 85,85,85,85 |
| Active Area | 216.96x135.6 mm | Touch / Glass | Projected Capacitive Multi Touch Screen |
| Environment | | | |
| Operating Humidity | 10% to 90% (Non-Condensing) | Operating Temperature | 0~50°C |
| Storage Temperature | -20°C~60°C | Shock | MIL-STD-810G Method 516.6 |
| Vibration | MIL-STD-810G Method 514.6 | IP rating | Front IP65 |
| Certification | | | |
| Certification | CE, FCC | | |
| IO Ports | | | |
| USB Port | 1 x USB for Touch Screen | Video | 1 x VGA 1 x HDMI (Optional) 1 x DVI (Optional) |
| Audio | 1 x Speaker (Optional) | | |
| Mechanical | | | |
| Dimension | 263.3 x 172 x 40.2 mm | Weight | 1.3 kg |
| Mounting | VESA Mount/ Panel Mount | Enclosure | Plastic Bezel & Aluminum back cover |
| Cooling System | Fanless Design | | |
| Accessory | | | |
| Accessory | 1 x VGA cable 1 x HDMI cable 100~240V AC to DC Adapter Power Cord Manual VESA screws(Varies by product) | Optional Accessory | Remote Controller (Optional,Varies by product) |
| Power | | | |
| Power Rating | 12V DC in 24V DC in (optional) | | |
| Control | | | |

Button 5 Keys: -, +, Power, Esc, Enter

DIMENSIONS UNIT:MM

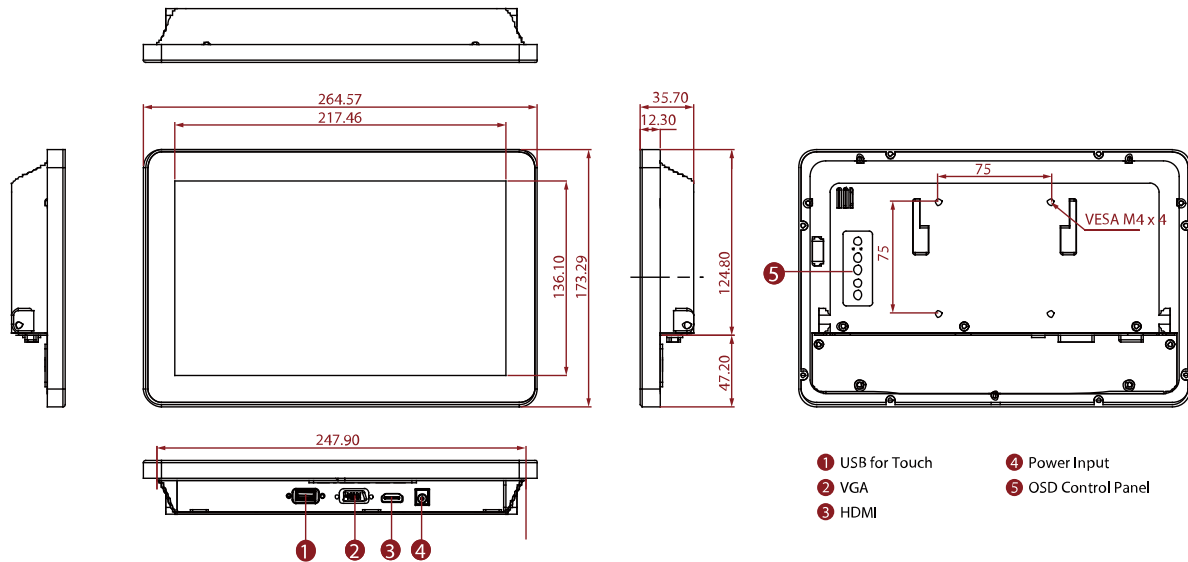

NOTE

1. This is a simplified drawing and some components are not marked in detail.
2. The product shown in this datasheet is a standard model. For diagrams that contain customized or optional I/O, please contact the Winmate Sales Team for more information.
3. All specifications are subject to change without prior notice.
4. The product shown in this datasheet is a standard model. For diagrams that contain customized or optional I/O, please contact the Winmate Sales Team for more information.

Assured Systems

Assured Systems is a leading technology company with over 1,500 regular clients in 80 countries, deploying over 85,000 systems to a diverse customer base in 12 years of business. We offer high-quality and innovative rugged computing, display, networking and data collection solutions to the embedded, industrial, and digital-out-of-home market sectors.

US

sales@assured-systems.com

Sales: +1 347 719 4508
Support: +1 347 719 4508

1309 Coffeen Ave
Ste 1200
Sheridan
WY 82801
USA

EMEA

sales@assured-systems.com

Sales: +44 (0)1785 879 050
Support: +44 (0)1785 879 050

Unit A5 Douglas Park
Stone Business Park
Stone
ST15 0YJ
United Kingdom

VAT Number: 120 9546 28
Business Registration Number: 07699660