



INDUSTRIAL TOUCH SCREEN MONITOR

VIO-110-MX200

10.4" SVGA 4:3 Resistive / Capacitive Touch Monitor with 2x 5W Speaker



Features

- 10.4" TFT SVGA 4:3 LCD with resistive 5-wire / projected capacitive touch
- 1x VGA, 1x HDMI, 1x DisplayPort, 1x USB 2.0, 1x COM, 1x Audio
- 9 to 48VDC wide range power input
- -10°C to 60°C extended operating temperature
- Designed with aluminum die-casting front frame
- IP65 compliant front panel
- Two 5W internal speakers built-in
- Multi-language OSD built-in

Specifications

Display

IP Rating	IP65
LCD Size	10.4" (4:3)
Max. Resolution	800 x 600 (SVGA)
Brightness (cd/m ²)	400
Contrast Ratio	700:1
LCD Color	16.2M
Pixel Pitch (mm)	0.264(H) x 0.264(V)
Viewing Angle	160/130
Backlight MTBF	70000 hrs (LED Backlight)

Touch

Projected Capacitive	VIO-110C-MX200
Resistive 5-Wire	VIO-110R-MX200

I/O

Audio	1x Audio Input
COM	1x COM Port Input (Resistive Touch Only)
USB	1x USB 2.0 (For Resistive Touch or P-CAP Touch)
DP	1x DisplayPort
HDMI	1x HDMI
VGA	1x VGA

Others Features

Speaker	AMP 5W + 5W
OSD	LCD On/Off, Auto, Menu, Up and Down Multi-language

Power

Power Adapter	Optional AC/DC 12V/5A, 60W
Power Management	Power Ignition Management
Power Mode	AT, ATX
Power Supply Voltage	9~48 VDC
Power Connector	3-Pin Terminal Block
Power Protection	OVP (Over Voltage Protection) OCP (Over Current Protection) Reverse Protection
Operating Temperature	-10 °C ~ 60 °C
Storage Temperature	-20 °C to 70 °C
Relative Humidity	10% ~ 80% (non-condensing)
IP Level	IP 65 Compliant Front Panel
Certification	CE, FCC Class A
Vibration	1.5 Grms, 5 - 500 Hz, 0.5 hr/axis
Shock	20G, half sine, 11ms

Physical

Dimensions	300 (W) x 238.5 (D) x 64.7 (H) mm
Weights	3.67 kg ~ 3.74 kg
Mounting Options	VESA Mounting Holes 75 x 75mm, 100 x 100mm

Available Models

- VIO-110R-MX200
10.4" 4:3 SVGA Resistive Touch Thin Frame Monitor with 2x 5W Speaker
- VIO-110C-MX200
10.4" 4:3 SVGA Capacitive Touch Thin Frame Monitor with 2x 5W Speaker

Optional Accessories

- 1-E09A06008
Adapter AC/DC 12V 5A 60W with 3pin Terminal Block Plug 5.0mm Pitch
- SFICBL022
Power Cord, 3-pin US Type, 180cm
- 1-TPCD00002
Power Cord, European Type
- 1-TPCD00001
Power Cord, 3-pin UK Type, 180cm

Packing List

- 1x VIO-110-MX200 Touch Monitor
- 6x Panel Mount Kit
- 1x USB Cable
- 1x VGA Cable
- 1x Screw Pack

* All specifications and photos are subject to change without notice.

External I/O Mechanical Layout

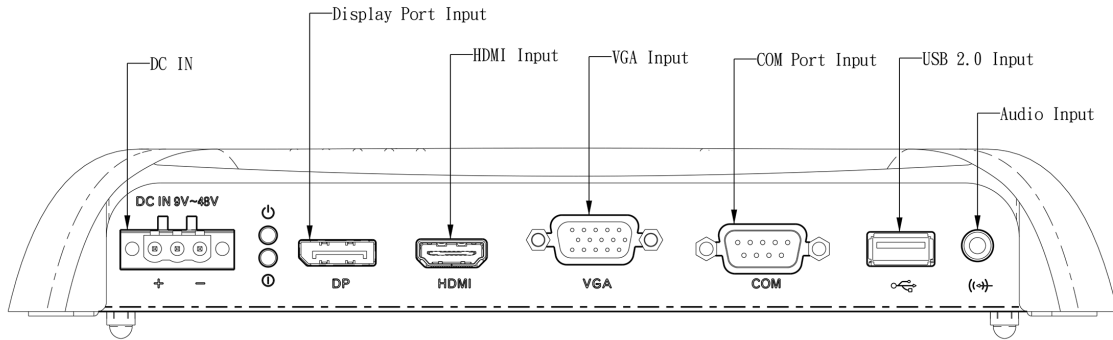

Dimension

Unit: mm

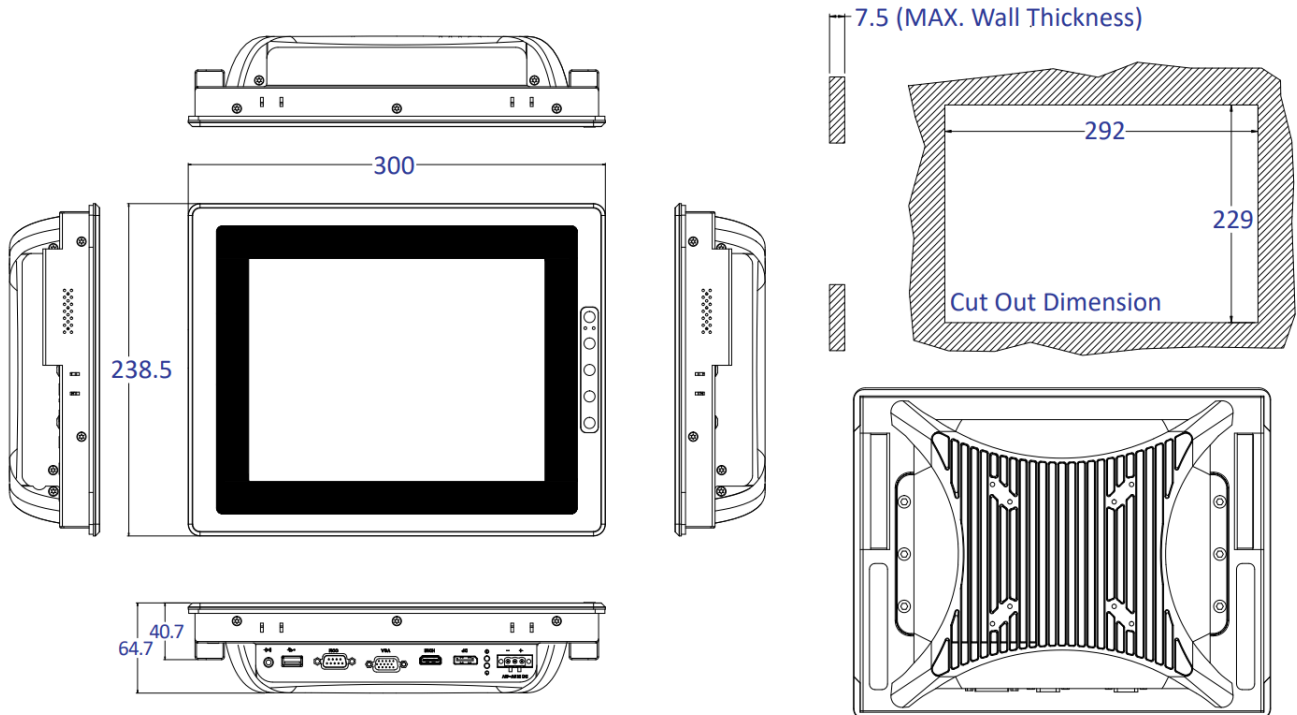

Assured Systems

Assured Systems is a leading technology company with over 1,500 regular clients in 80 countries, deploying over 85,000 systems to a diverse customer base in 12 years of business. We offer high-quality and innovative rugged computing, display, networking and data collection solutions to the embedded, industrial, and digital-out-of-home market sectors.

US

sales@assured-systems.com

Sales: +1 347 719 4508
Support: +1 347 719 4508

1309 Coffeen Ave
Ste 1200
Sheridan
WY 82801
USA

EMEA

sales@assured-systems.com

Sales: +44 (0)1785 879 050
Support: +44 (0)1785 879 050

Unit A5 Douglas Park
Stone Business Park
Stone
ST15 0YJ
United Kingdom

VAT Number: 120 9546 28
Business Registration Number: 07699660