

# GOT815W-511 NEW

15.6" FHD TFT IP66 & IP69K-rated Stainless Steel Fanless PCT (or Resistive Touch) Panel Computer with Intel® Core™ i5-7300U Processor and Flat Bezel Design (-20°C to +50°C)

## Features

- 15.6" FHD TFT flat bezel LCD display
- IP66/IP69K-rated (NEMA 4X) water/dust/corrosion-proof design
- Full stainless steel enclosure with type 316
- -20°C to +50°C wide operating temperature range
- Fanless design with Intel® Core™ i5-7300U processor
- Optional Wi-Fi/3G kit for wireless network connectivity
- 9 to 36 VDC wide range power input
- Supports VESA mount
- M12 type connectors for harsh environments

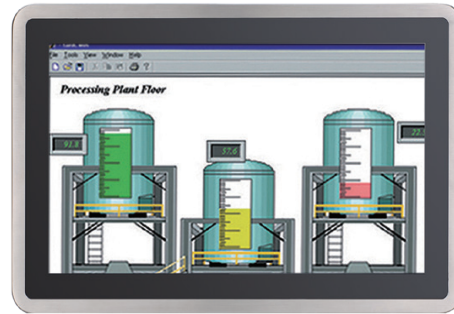

▲ Side view

1. Backlight on/off
2. Brightness adjust +/-
3. Power on/off



4. DC power connector
5. 1 x LAN
6. 1 x RS-232/422/485 (default RS-232)
7. 1 x RS-232/422/485 (default RS-232)
8. 2 x USB 2.0
9. 2 x USB 2.0



## Introduction

The 15.6-inch GOT815W-511 is specially designed for food processing applications. Its IP66-rated stainless steel housing protects entire system from damage of water, powder and dust. It also supports a wide operating temperature range from -20°C to +50°C. Thus, this robust unit is specifically designed for high humidity, dusty or wet spaces in food factories or kitchens and more harsh applications.

### Full IP66 and IP69K Certified

The GOT815W-511 adopts a water/dust-proof housing design with five IP66-rated M12 I/O connectors and IP69K that ensures the product's ability to resist ingress of high temperature and high pressure water. It passed entire system IP66 test by SGS, and verified salt mist test. Additionally, it was tested by a spray nozzle with high temperature water (+80°C), a flow rate of 14 to 16 L/min and a nozzle hold with distance 10 to 15 cm away from the device at angles of 0°, 30°, 60° and 90° for 30 seconds. The GOT815W-511 is qualified to meet harsh environment applications.

### Wide Temperature (-20°C to +50°C) & Anti-vibration (1G) Design

The GOT815W-511 featuring fanless and noiseless design supports a wide operating temperature range from -20°C to +50°C. Besides, the patent of anti-vibration for SSD ensures system reliability and stability.

## Specifications

Enclosure	Stainless type 316	
LCD Panel	Display Type	15.6" FHD TFT LCD
	Brightness (cd/m <sup>2</sup> )	400 nits
	Resolution	1920 x 1080
	Viewing Angle (H/V)	160°/140°
Main System	CPU	Intel® Core™ i5-7300U 2.6 GHz, up to 3.5 GHz (Kaby Lake)
	Chipset	SoC integrated
	System Memory	1 x 260-pin DDR4-2133 SO-DIMM, up to 16GB
	BIOS	AMI UEFI BIOS
	Storage	1 x 2.5" SSD HDD or 1 x 2.5" SATA HDD (9.5 mm height)
	Watchdog Timer	255 levels, 1 to 255 sec.
	Onboard Graphics	Integrated in Intel® GFX

### Specifications

I/O Connector	2 x RS-232/422/485 (default RS-232, A-coded) 4 x USB 2.0 (A-coded) 1 x 10/100/1000 Mbps Ethernet supporting PXE and LAN wake-up (Intel® I210-IT; X-coded) 1 x DC power connector (M12)
Expansion Interface	1 x Full-size PCI Express Mini Card slot 1 x Half-size PCI Express Mini Card slot
Touchscreen	5-wire resistive touch or projected capacitive multi-touch
Power Input	9 to 36 VDC
Power Consumption	58.5W
Dimensions	414.8 mm (16.4") (W) x 55mm (2.2") (D) x 265.1 mm (10.43") (H)
Packing Dimensions	535mm (21.06") (W)* 196mm (7.71") (D) * 485mm (19.1") (H)
Weight (net/gross)	6.3 kg (13.88 lb)/7.5 kg (16.53 lb)
Operating Temperature	-20°C to +50°C (-4°F to +122°F)
Relative Humidity	10% - 95% @ +40°C, non-condensing
Operation Vibration	1G, 5 - 500Hz, random for 2.5" SSD
Certifications	CE

\*W.T.: Wide temperature. All W.T. supported products have to be sorted by Axiomtek.

### Packing List

- 1 x GOT815W-511
- 1 x DC cable

### Ordering Information

GOT815W-511-C-DC (P/N: E22B815123)	15.6" FHD fanless IP66 & IP69K-rated stainless steel touch panel computer with Intel® Core™ i5-7300U, projected capacitive touch screen, 400 nits LCD and 9 to 36 VDC power input
---------------------------------------	---

\* Other configuration by request

\* Specification and certifications may vary based on different requirements

### Optional Accessories

594B8122100E	Water-proof COM cable (1.8 m)
594B8152710E	Water-proof LAN cable (1.8 m)
594B8152820E	Water-proof USB cable (1.8 m)
50966224010E	Adapter 24V 90W, M12 A-code 5P FSP090AAAN3

### Optional EOS Installation

Windows® 10 IoT

### Optional OS Installation

Windows® 10

### Dimensions

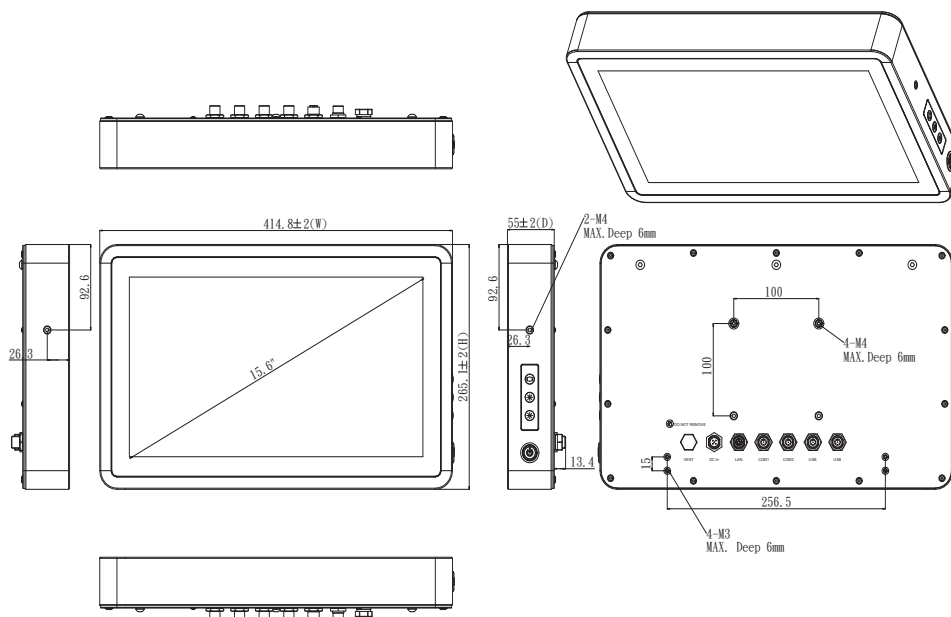

## Assured Systems

Assured Systems is a leading technology company with over 1,500 regular clients in 80 countries, deploying over 85,000 systems to a diverse customer base in 12 years of business. We offer high-quality and innovative rugged computing, display, networking and data collection solutions to the embedded, industrial, and digital-out-of-home market sectors.

### US

[sales@assured-systems.com](mailto:sales@assured-systems.com)

Sales: +1 347 719 4508  
Support: +1 347 719 4508

1309 Coffeen Ave  
Ste 1200  
Sheridan  
WY 82801  
USA

### EMEA

[sales@assured-systems.com](mailto:sales@assured-systems.com)

Sales: +44 (0)1785 879 050  
Support: +44 (0)1785 879 050

Unit A5 Douglas Park  
Stone Business Park  
Stone  
ST15 0YJ  
United Kingdom

VAT Number: 120 9546 28  
Business Registration Number: 07699660