

LNP-0500G-bt-24 Series

5-Port Industrial Gigabit IEEE 802.3bt PoE++ Unmanaged Ethernet Switch, with 4*10/100/1000Tx (90W/Port) and 1*10/100/1000Tx; 12~55VDC Power Input



Features

- ▶ Supports 4*10/100/1000Tx IEEE 802.3bt Compliant with 90W/Port and 1*10/100/1000Tx Ethernet Port
- ▶ Store-and-Forward Switching Architecture
- ▶ 10Gbps Back-Plane (Switching Fabric)
- ▶ 8K MAC Address Table
- ▶ 10.0Kbytes Jumbo Frame Support
- ▶ Redundant Power Input Design: 12~55VDC
- ▶ Built-in 1 Relay Output for Power Failure Warning
- ▶ IP30 Rugged Metal Case Design
- ▶ DIN-Rail and Wall Mount Support Included
- ▶ Operating Temp. - STD: -10°~65°C, EOT: -40°~75°C
- ▶ 5-Year Warranty

INTRODUCTION

Antaira Technologies' LNP-0500G-bt-24 series is an industrial gigabit PoE++ unmanaged Ethernet switch featuring 4*10/100/1000Tx Gigabit Ethernet ports that support IEEE802.3bt for a maximum of 90W/port and 1*10/100/1000Tx Ethernet port. The LNP-0500G-bt is an ideal solution for rapid, unmanaged gigabit network expansion with PoE++ capabilities.

The LNP-0500G-bt-24 series is IP30 rated and DIN-rail mountable. There are also two operating temperature models for either a standard temperature range (STD: -10°C to 65°C) or an extended temperature range (EOT: -40°C to 75°C). It also provides Ethernet connectivity with PoE functions for outdoor or harsh industrial automation application environments, such as security surveillance, ITS-traffic monitoring systems, oil/gas and mining, facility management for power/utility, water wastewater treatment plants, and lastly, automated production lines in factory automation.

DIMENSIONS

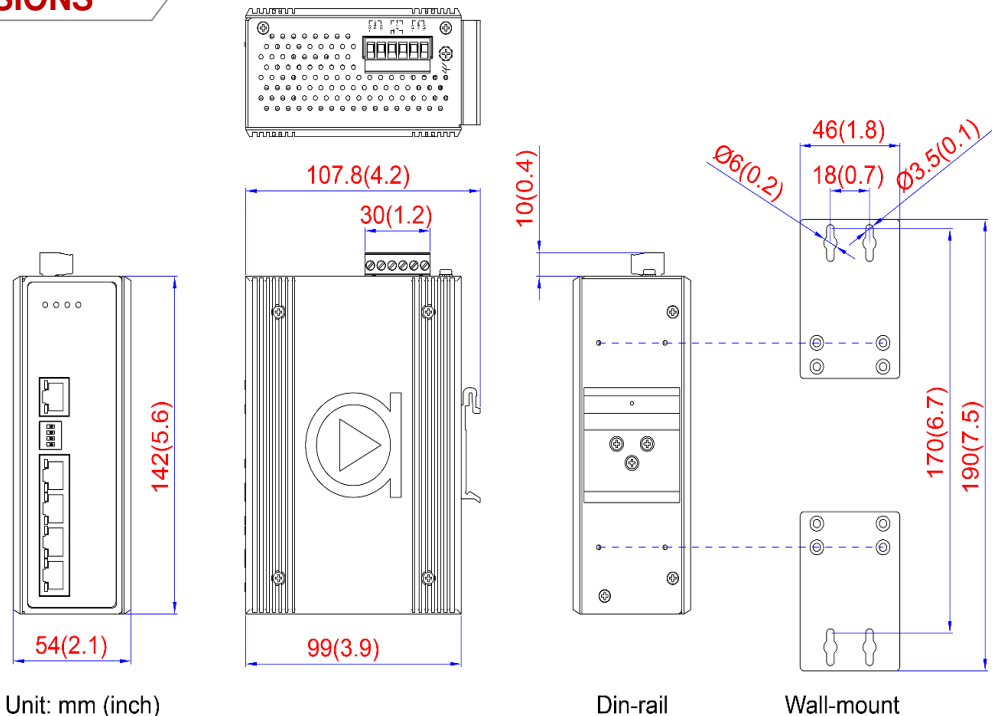

SPECIFICATIONS

Technology	IEEE 802.3 10Tx Ethernet
Standards	IEEE 802.3u 100Tx Fast Ethernet IEEE 802.3ab 1000Tx Gigabit Ethernet IEEE 802.3at/af/bt Power over Ethernet
Processing Type	Store and Forward
Flow Control	IEEE 802.3x back pressure flow control
Switch Properties	
Switch Architecture	Back-Plane (Switching Fabric): 10.0Gbps 14,880pps for 10Base-T Ethernet 148,800pps for 100Base-T Fast Ethernet 1,488,000pps for 1000Base-T Gigabit Ethernet
Transfer Rate	
Packet Buffer	1Mbit
Jumbo Frame	10Kbytes
MAC Table Size	8K
Port Interface	
Ethernet RJ45 Port	4*10/100/1000Tx (PSE: 90W/Port) + 1*10/100/1000Tx auto negotiation speed, Full/Half duplex mode, and auto MDI/MDI- X connection
PoE Pin Out	V-, V-, V+, V+, for pin 1, 2, 3, 6 V+, V+, V-, V-, for pin 4, 5, 7, 8
DIP Switch	Control PoE Function by Port System: Power 1, Power 2, Fault, PoE Load (P/L)
LED Indicators	Ethernet Ports: Speed/Link/Active PoE: On-connected to PD devices
Relay Contact	24VDC, 1A resistive 10Base-T: 2-pair UTP/STP Cat. 3, 4, 5 cable EIA/TIA-568 100-ohm (100m) 100Base-TX: 2-pair UTP/STP Cat. 5 cable EIA/TIA-568 100-ohm (100m) 1000BaseTX: UTP/STP Cat.5/E cable EIA/TIA-568 100-ohm (100m)
Network Cable	

Mechanical Characteristics	
Housing	Metal, IP30 protection
Dimension	54 x 142 x 99 mm
Weight	Unit: 1.85 lbs.; Shipping: 2.51 lbs.
Mounting	DIN-Rail mounting, Wall mounting
Power Requirement	
Input Voltage	12~55VDC Redundant Input
Power Connection	1 removable 6-contact terminal block
Overload Current Protection	Present
Power Reverse Polarity Protection	Present
Power Consumption	5W
Max PoE Power Budget	90W @12VDC 180W @24~55VDC
PoE Power Output	90W max. per PoE port
PoE Port Priority	Port 1>Port 2>Port 3>Port 4
Environmental Limits	
Operating Temperature	STD: -10 to 65°C EOT: -40 to 75°C
Storage Temperature	-40°C ~ 85°C
Ambient Relative Humidity	5 to 95%, (non-condensing)
Regulatory Approvals	
EMI	FCC Part 15 Subpart B Class A, CE EN55032/EN61000-6-4 Class A
EMS	CE EN55035/EN61000-6-2 Class A, IEC61000-4-2,3,4,5,6,8
Free Fall	IEC60068-2-32
Shock	IEC60068-2-27
Vibration	IEC60068-2-6
Green	RoHS Compliant
Certifications	FCC, CE
Warranty	5 Years

ORDERING INFO

LNP-0500G-bt-24	5-Port Industrial Gigabit PoE++ Unmanaged Ethernet Switch, with 4*10/100/1000Tx (90W/Port) and 1*10/100/1000Tx, 12~55VDC Power Input
LNP-0500G-bt-24-T	5-Port Industrial Gigabit PoE++ Unmanaged Ethernet Switch, with 4*10/100/1000Tx (90W/Port) and 1*10/100/1000Tx, 12~55VDC Power Input; EOT: -40°C to 75°C

Assured Systems

Assured Systems is a leading technology company with over 1,500 regular clients in 80 countries, deploying over 85,000 systems to a diverse customer base in 12 years of business. We offer high-quality and innovative rugged computing, display, networking and data collection solutions to the embedded, industrial, and digital-out-of-home market sectors.

US

sales@assured-systems.com

Sales: +1 347 719 4508
Support: +1 347 719 4508

1309 Coffeen Ave
Ste 1200
Sheridan
WY 82801
USA

EMEA

sales@assured-systems.com

Sales: +44 (0)1785 879 050
Support: +44 (0)1785 879 050

Unit A5 Douglas Park
Stone Business Park
Stone
ST15 0YJ
United Kingdom

VAT Number: 120 9546 28
Business Registration Number: 07699660