

Airolinx APN-200

Industrial 802.11b/g Wireless LAN Access Point with 2-Port LAN



Features

- ▶ Supports up to 54Mbps Link Speed
- ▶ WEP / WPA / WPA-PSK (TKIP, AES) / WPA2 / WPA2-PSK (TKIP, AES) / 802.1x / RADIUS Support
- ▶ Supports AP / Bridge / Repeater Mode
- ▶ Daisy Chain Support to Reduce Usage of Switch Ports
- ▶ Redundant Power Inputs: 12 ~ 48VDC on Terminal Block
- ▶ Fully Compliant with IEEE 802.3af (APN-200P Only)
- ▶ Secured Management by HTTPS
- ▶ Event Warnings by Syslog, Email, SNMP Trap, Relay and Beeper
- ▶ 5-Year Warranty



▶ Dimensions (unit = mm)

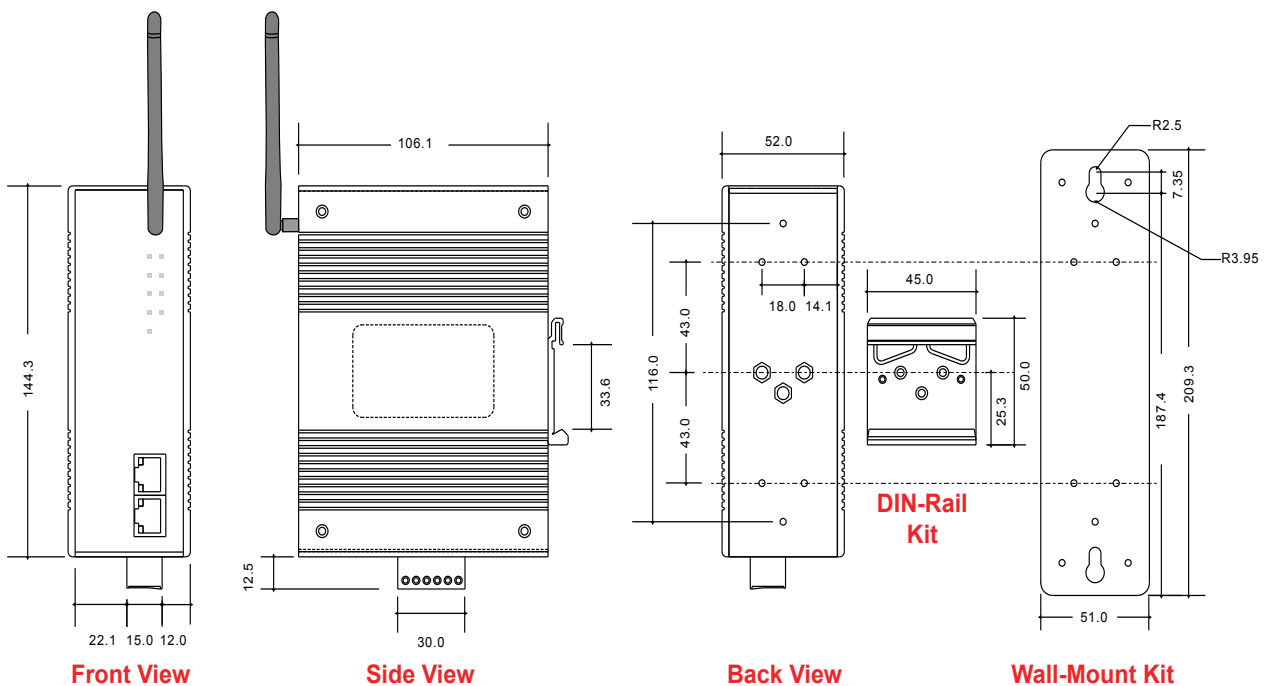

► Specifications

Ethernet Port

2 x 10/100BaseT(X) which supports Switch Mode

Connector

RJ-45

Protection

Built-in 1.5KV Magnetic Isolation

Protocol

ICMP, IP, TCP, UDP, DHCP, BootP, ARP/RARP, DNS, SNMP MIB II, HTTPS, SNMP v1/v2, Trap, Private MIB

Power over Ethernet (P.O.E.)

Present at ETH2

Power Device (IEEE 802.3af):

- IEEE 802.3af Compliant Input Interface
- Power Consumption: 8 Watts Max.
- Overload & Short Circuit Protection
- Isolation Voltage: 1000 VDC Min.
- Isolation Resistance: 10⁸ ohms Min.

LED

PWR 1(2) (P.O.E.) / Ready, ETH (1) Link/ACT, WLAN Link/ACT, Fault

WLAN Operating Mode

AP / Bridge / Repeater

Antenna Connector

Reverse SMA

Radio Frequency Type

DSSS

Modulation

IEEE 802.11b: CCK, DQPSK, DBPSK

IEEE 802.11g: OFDM w/ BPSK, QPSK, 16QAM, 64QAM

Frequency Band

America/FCC: 2.412 ~ 2.462 GHz (11 Channels)

Europe CE/ETSI: 2.412 ~ 2.472 GHz (13 Channels)

Transmission Rate

IEEE 802.11b: 1 / 2 / 5.5 / 11 Mbps

IEEE 802.11g: 6 / 9 / 12 / 18 / 24 / 36 / 48 / 54 Mbps

Transmit Power

18 dBm

Receiver Sensitivity

-81 dBm @ 11 Mbps, PER < 8%

-64 dBm @ 54 Mbps, PER < 10%

Encryption Security

WEP: 64-bit, 128-bit Key Supported

WPA / WPA2: 802.11i (WEP and AES Encryption)

PSK (256-bit Key Pre-shared Key Supported)

802.1x and RADIUS Supported

TKIP Encryption

Wireless Security

SSID Broadcast Disable

Power Input

12 ~ 48VDC in 6-Pin Terminal Block

Power Consumption

6 Watts Max.

Reverse Polarity Protection

Present

Operation Temperature

Standard: 0° C to 60° C (32° F to 140° F)

Wide Operating Temperature: -35° C to 70° C (-31° F to 158° F)

Operation Humidity

5% to 95% (Non-condensing)

Storage Temperature

-35° C to 85° C

Casing

IP30 Protection

Dimension (W x H x D)

52 x 144 x 106 mm (2.05 x 5.67 x 4.17 in.)

Stability Testing

Shock: IEC60068-2-27

Free Fall: IEC60068-2-32

Vibration: IEC60068-2-6

EMI

FCC Part 15, CISPR (EN55022) Class A

EMS

CE EN61000-4-2/EN61000-4-3/EN61000-4-4/EN61000-4-5/EN61000-4-6

MTBF

200,000 Hours at Minimum

Warranty

5-Year Warranty

► Ordering Information

APN-200

Industrial 802.11b/g Wireless LAN Access Point with 2-Port LAN

APN-200P

Industrial 802.11b/g Wireless LAN Access Point with 1-Port LAN and 1-Port P.O.E.

APN-200-T

Industrial 802.11b/g Wireless LAN Access Point with 2-Port LAN, Wide Operating Temperature

APN-200P-T

Industrial 802.11b/g Wireless LAN Access Point with 1-Port LAN and 1-Port P.O.E., Wide Operating Temperature

Optional Accessories

DR-4524

45W 24VDC Industrial DIN Rail Power Supply

DR-75-24

75W 24VDC Industrial DIN Rail Power Supply

DR-120-24

120W 24VDC Industrial DIN Rail Power Supply

Aaxeon Technologies

445 Capricorn St.
Brea, CA 92821
USA

Toll-Free: (877) AAXEON5 (229-3665)

Phone: (714) 671-9000

FAX: (714) 671-9944

e-Mail: info@aaxeon.com

aaxeon
www.aaxeon.com

Assured Systems

Assured Systems is a leading technology company with over 1,500 regular clients in 80 countries, deploying over 85,000 systems to a diverse customer base in 12 years of business. We offer high-quality and innovative rugged computing, display, networking and data collection solutions to the embedded, industrial, and digital-out-of-home market sectors.

US

sales@assured-systems.com

Sales: +1 347 719 4508
Support: +1 347 719 4508

1309 Coffeen Ave
Ste 1200
Sheridan
WY 82801
USA

EMEA

sales@assured-systems.com

Sales: +44 (0)1785 879 050
Support: +44 (0)1785 879 050

Unit A5 Douglas Park
Stone Business Park
Stone
ST15 0YJ
United Kingdom

VAT Number: 120 9546 28
Business Registration Number: 07699660